



AURORA[®] PVM(X) SERIES VERTICAL MULTISTAGE PUMPS



Certified to
NSF/ANSI 61 & 372

PVMX1
through
PVMX33 Only

THIS PAGE INTENTIONALLY LEFT BLANK

A LEADER IN WATER TECHNOLOGY

Pentair is one of the world's leading companies in the planning and manufacture of innovative products and systems suitable in any situation requiring the treatment, transportation and storage of water. The activity and success of Pentair is based on values such as constant improvement, the continuous development of new products, high-performance, competence, business ethics and market leadership. Pentair's employees share personal values such as accountability, deep respect for people and the environment and a candid and practical work style. Strong customer relationships and high quality standards allow Pentair to rank amongst the leading producers of technology and instruments for water treatment.



FLOW TECHNOLOGIES

Vertical and horizontal centrifugal pumps; submersible pumps for domestic, commercial, agricultural and industrial use; pumps for the drainage of clear and wastewaters; pressure booster units and fire-fighting systems.



FILTRATION

Industrial, residential and commercial filtration systems; filter cartridges, components for the filtration of drinking water, pumps for mobile homes and boats and pumps and accessories for applications in industry and the catering service.

SAFE, CLEAN WATER

Providing clean, safe water to an ever-growing portion of the population is the Mission of Pentair: a valid organization is engaged to serve our customers in an efficient manner through production plants located in every corner of the world and specialized sales and marketing networks.



WATER TREATMENT

Residential, commercial and industrial water conditioning control valves; fibre-glass wound expansion tanks and vessels; water storage tanks.



POOL AND SPA

A complete range of pool/spa equipment and accessories: filters, pumps, heating and lighting systems and cleaning accessories; dosing and control systems and products and accessories for fountains and ponds.

PVM(X) VERTICAL MULTISTAGE CENTRIFUGAL PUMPS

HIGH HYDRAULIC EFFICIENCY, MOTOR DESIGNED TO NEMA STANDARDS

The PVM and PVMX are vertical multistage pumps with flanged/NPT or grooved connections.

Stage construction with stainless steel impellers, chambers and pressure casing. Pump shaft and motor shaft of the NEMA-standard motor are directly close coupled.

All pumps are equipped with a cartridge type mechanical seal for easy maintenance.

PVM and PVMX pumps have different pump sizes and various numbers of stages to provide the flow and the pressure required.

APPLICATIONS

- Water supply
- Pressure boosting systems
- Water treatment/filtration
- Irrigation
- High pressure washes
- Liquid transfer
- Firefighting systems
- Boiler feed



PVM(X)

VERTICAL MULTISTAGE CENTRIFUGAL PUMPS

IDENTIFICATION CODE

The attached Aurora® PVM multistage pump pages include a new pump nomenclature and set of part numbers which will allow you to order pumps with a pre-configured set of product features.

Materials: Cast Iron
Motor Phase: 1 Ph

Part Number Nomenclature

Example: PVM X - 3 - 102

- PVM** - Aurora Vertical Multistage
- X** - ALL 316 SST construction

Connection			Flange							
Elastomer			EPDM				Viton			
Series	Stages	HP	Pump End ONLY	ODP	TEFC	TEFC Pr. Eff.	Pump End ONLY	ODP	TEFC	TEFC Pr. Eff.
			-100	-101	-102		-300	-301	-302	
PVM1-2	2	0.50	\$860		\$1,301		\$901		\$1,342	
PVM1-3	3	0.50	902	Not Available	1,343	Not Available	943	Not Available	1,384	Not Available
PVM1-4	4	0.50	973		1,414		1,014		1,455	
PVM1-5	5	0.75	1,042		1,549		1,083		1,590	

1	Flow Series	BEP (GPM)	Flow Series	BEP (GPM)
	1	10.4	15	97
	3	16	20	106
	5	30	33	145
	10	55		

3 - Staging

First digit or digits (example '3') designates the number of stages that the pump is built with. For pumps built with multiple impeller sizes, they are designated by the number of total impellers followed by the number of stages with the smaller impeller size. Example: PVM33-5-2 has 5 impellers, 2 of which are the smaller impeller size.

102 - Configurable options

Last three (3) digits describe the required pump connections, elastomers and motor enclosure and voltage requirements. In this example from page 3 (illustrated in the chart below), '102' represents: flange, EPDM elastomers, TEFC 115/280V 1 ph motor. Please consult the price sheet for details.

PERFORMANCE RANGE

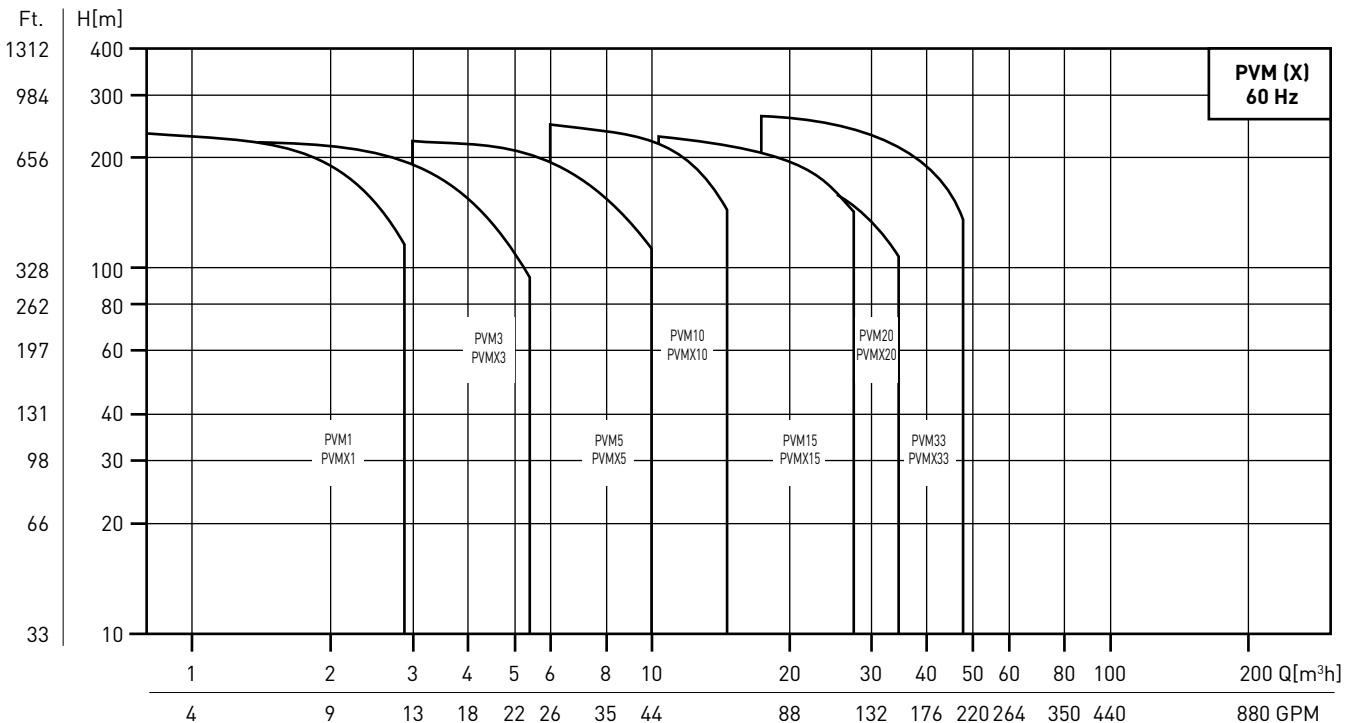

PVM(X)

VERTICAL MULTISTAGE CENTRIFUGAL PUMPS

MOTOR

- TEFC motors with enclosed stator and external ventilation
- Main dimensions are in accordance with NEMA standards
- Class B insulation
- Maximum standard environment temperature 40° C
- Speed of rotation 3500 rpm

Motor Type: 2-pole						
HP	Phase	Voltage	Frame Size	Phase	Voltage	Frame Size
0.5	1	115V/208-230V	56C	3	208-230V/460V	56C
0.75	1	115V/208-230V	56C	3	208-230V/460V	56C
1	1	115V/208-230V	56C	3	208-230V/460V	56C
1.5	1	115V/208-230V	56C	3	208-230V/460V	56C
2	1	115V/208-230V	56C	3	208-230V/460V	56C
3	1	115V/208-230V	182TC	3	208-230V/460V	182TC
5	1	208-230V	213TC	3	208-230V/460V	184TC
7.5	1	208-230V	213TC	3	208-230V/460V	213TC
10	1	208-230V	215TC	3	208-230V/460V	215TC
15	Not Available			3	208-230V/460V	254TC
20				3	230V/460V	254TC
25				3	230V/460V	284TSC
30				3	230V/460V	284TSC
40				3	230V/460V	284TSC
50				3	230V/460V	326TSC (TEFC) 324TSC (ODP)
60				3	230V/460V	364TSC (TEFC) 324TSC (ODP)
75				3	230V/460V	365TSC (TEFC) 364TSC (ODP)
100				3	230V/460V	405TSC (TEFC) 365TSC (ODP)

PVM(X)

VERTICAL MULTISTAGE CENTRIFUGAL PUMPS

PRODUCT DATA

60Hz	PVM(X)						
	1	3	5	10	15	20	33
Nominal Flow – US GPM	8.8	16	32	53	93	106	160
Flow Range – US GPM	1-20	6.5-30	13-60	25-95	45-150	50-170	80-225
Max. Pressure – psi (ft)	360 (832)	360 (832)	360 (832)	360 (832)	360 (832)	360 (832)	435 (1005)
Fluid Temperature – °F (°C)	5°F to + 250°F (-15°C to + 120°C)						
Motor Power – hp	0.5-3	0.5-5	0.75-7.5	0.75-15	2-25	3-25	5-40
Version							
PVM: Cast Iron	•	•	•	•	•	•	•
PVMX: Stainless Steel EN 1.4401/AISI 316"	•	•	•	•	•	•	•
Motor							
Main Connection, 3 Phase	208-230V/460V (0.5-15 hp) 230V/460V (20-100 hp)						
Insulation Class	B						
Ambient Temperature	40°C						
PVM Pipe Connection							
Flange Raised Face	1-1/4" ANSI 250#	1-1/4" ANSI 250#	1-1/4" ANSI 250#	2" ANSI 250#	2" ANSI 250#	2" ANSI 250#	2-1/2" ANSI 250#
NPT	1-1/4" NPT Female	1-1/4" NPT Female	1-1/4" NPT Female	2" NPT Female	2" NPT Female	2" NPT Female	-
PVMX Pipe Connection							
Flange Raised Face	1-1/4 ANSI 300#	1-1/4 ANSI 300#	1-1/4 ANSI 300#	2" ANSI 300#	2" ANSI 300#	2" ANSI 300#	2-1/2" ANSI 300#
Grooved Connection	R¼ DN32	R¼ DN32	R¼ DN32	R2 DN50	R2 DN50	R2 DN50	N/A
Mechanical Seals							
SiC/SiC	Standard						
Seals							
EPDM	Standard						
Viton	Optional						

PVM(X)

VERTICAL MULTISTAGE CENTRIFUGAL PUMPS

PUMP CONSTRUCTION

POS.	NAME	MATERIAL	PVM 1, 3, 5, 10, 15, 20	PVMX 1, 3, 5, 10, 15, 20
36	Pump Head	Cast Iron	EN-GJL-200 ; ASTM 25B	EN-GJS-450-10 ; ASTM 65-45-12
56	Pump Head Cover	Stainless Steel	-	1.4401 ; AISI 316
18	Impeller	Stainless Steel	1.4301 ; AISI 304	1.4401 ; AISI 316
37	Shaft	Stainless Steel	1.4057 ; AISI 431	1.4401 ; AISI 316
48	Outer Sleeve	Stainless Steel	1.4301 ; AISI 304	1.4401 ; AISI 316
82	O-Ring for Outer Sleeve	EPDM	-	-
12	Chamber	Stainless Steel	1.4301 ; AISI 304	1.4401 ; AISI 316
24	Neck Ring	PTFE	-	-
59	Base	Cast Iron	EN-GJL-200 ; ASTM 25B	-
		Stainless Steel	-	1.4401 ; AISI 316
62	Base Plate	Cast Iron	-	EN-GJL-200 ; ASTM 25B
44	Coupling	Fe-Cu-C	SINT C11 ; MPIF FC0525	SINT C11 ; MPIF FC0525
57	Mechanical Seal	Cartridge Type	-	-

PVM - 1, 3, 5, 10, 15, 20

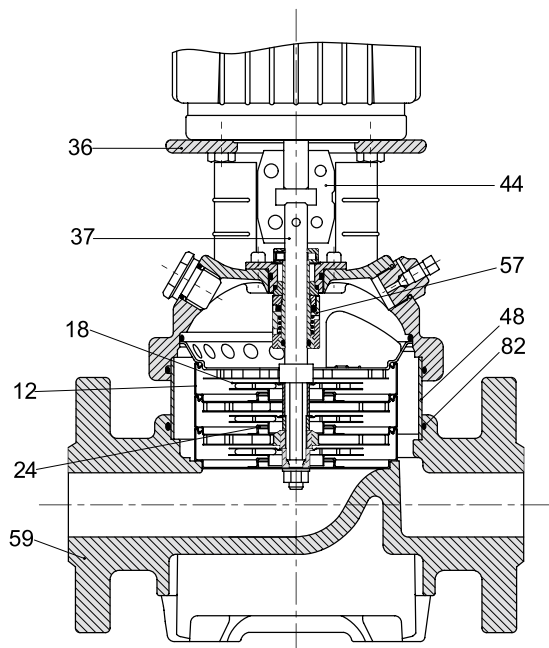

PVMX - 1, 3, 5, 10, 15, 20

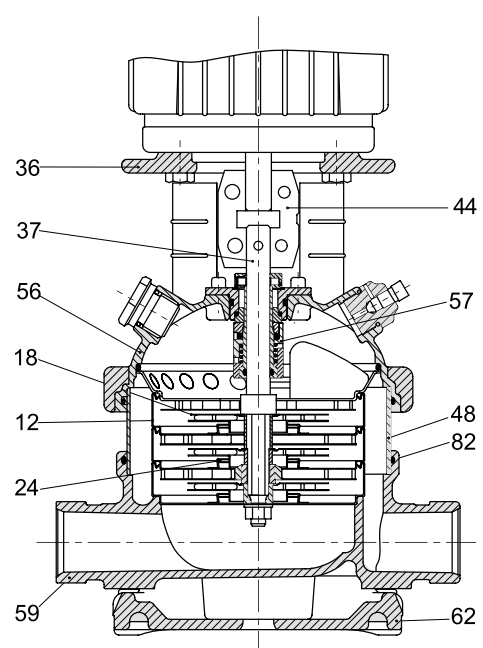

PVM(X)

VERTICAL MULTISTAGE CENTRIFUGAL PUMPS

PUMP CONSTRUCTION

POS.	NAME	MATERIAL	PVM 33	PVMX 33
36	Pump Head	Cast Iron	EN-GJL-250 ; ASTM 35B	-
		Stainless Steel	-	1.4401 ; AISI 316
53	Motor Bracket	Cast Iron	EN-GJL-250 ; ASTM 35B	EN-GJL-250 ; ASTM 35B
18	Impeller	Stainless Steel	1.4301 ; AISI 304	1.4401 ; AISI 316
37	Shaft	Stainless Steel	1.4057 ; AISI 431	1.4401 ; AISI 316
48	Outer Sleeve	Stainless Steel	1.4301 ; AISI 304	1.4401 ; AISI 316
82	O-Ring for Outer Sleeve	EPDM	-	-
12	Chamber	Stainless Steel	1.4301 ; AISI 304	1.4401 ; AISI 316
24	Neck Ring	Carbon Fiber + POB + PTFE	-	-
59	Base	Cast Iron	EN-GJL-250 ; ASTM 35B	-
		Stainless Steel	-	1.4401 ; AISI 316
62	Base Plate	Cast Iron	-	EN-GJL-250 ; ASTM 35B
57	Mechanical Seal	Cartridge Type	-	-
14	Bearing Ring	-	Bronze	POB + Grphite + PTFE
42	Bottom Bearing Ring	Tungsten Carbide/ Tungsten Carbide	-	-

PVM - 33

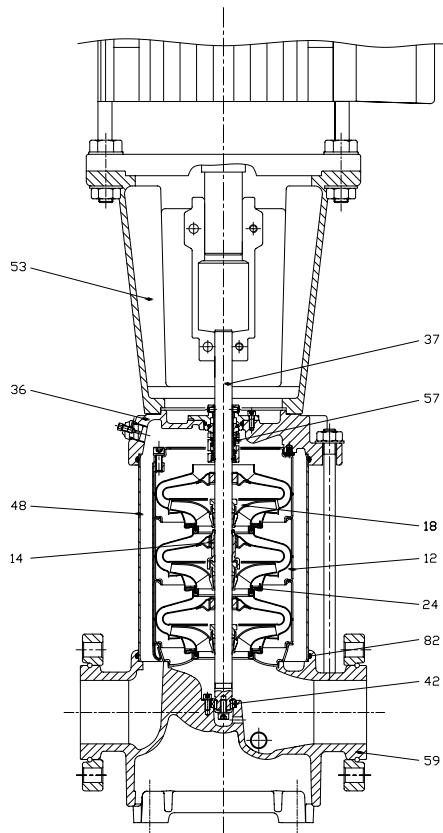

PVM(X) - 33

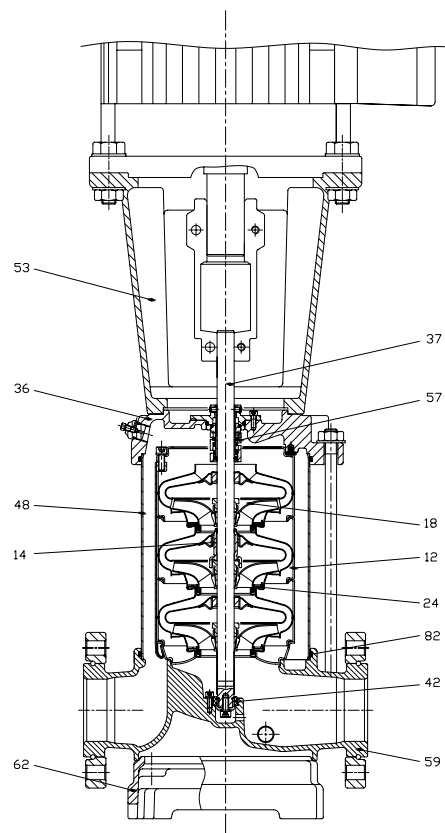

PVM(X) 1

VERTICAL MULTISTAGE CENTRIFUGAL PUMPS

PUMP DIMENSIONS – STANDARD

Model Number	Motor HP	Motor Service Factor	Phase	Voltage	Motor Frame	PVM Cast Iron							PVMX Stainless Steel								
						Dimensions in inches						Weight in Lbs		Dimensions in inches						Weight in Lbs	
						A	B	C	D	E	F	Pump End Only	Pump & Motor	A	B	C	D	E	F	Pump End Only	Pump & Motor
PVM(X)1-2	0.5	1.25	1	115V/208-230V	56C	11.0	9.3	6.0	2.1	22.4	6.0	38	59	11.1	9.3	6.0	2.1	22.5	6.0	32	53
PVM(X)1-2	0.5	1.25	3	208-230V/460V	56C	11.0	10.2	6.6	2.1	23.2	6.6	38	73	11.1	10.2	6.6	2.1	23.3	6.6	32	67
PVM(X)1-3	0.5	1.25	1	115V/208-230V	56C	11.0	9.3	6.0	2.1	22.4	6.0	39	60	11.1	9.3	6.0	2.1	22.5	6.0	33	54
PVM(X)1-3	0.5	1.25	3	208-230V/460V	56C	11.0	10.2	6.6	2.1	23.2	6.6	39	74	11.1	10.2	6.6	2.1	23.3	6.6	33	68
PVM(X)1-4	0.5	1.25	1	115V/208-230V	56C	11.7	9.3	6.0	2.1	23.1	6.0	40	61	11.8	9.3	6.0	2.1	23.2	6.0	35	56
PVM(X)1-4	0.5	1.25	3	208-230V/460V	56C	11.7	10.2	6.6	2.1	23.9	6.6	40	75	11.8	10.2	6.6	2.1	24.0	6.6	35	70
PVM(X)1-5	0.5	1.25	1	115V/208-230V	56C	12.4	9.3	6.0	2.1	23.8	6.0	42	63	12.5	9.3	6.0	2.1	23.9	6.0	36	57
PVM(X)1-5	0.5	1.25	3	208-230V/460V	56C	12.4	10.2	6.6	2.1	24.6	6.6	42	77	12.5	10.2	6.6	2.1	24.7	6.6	36	71
PVM(X)1-6	0.75	1.25	1	115V/208-230V	56C	13.1	9.9	6.0	2.1	25.1	6.0	43	72	13.2	9.9	6.0	2.1	25.2	6.0	37	66
PVM(X)1-6	0.75	1.25	3	208-230V/460V	56C	13.1	10.2	6.6	2.1	25.3	6.6	43	73	13.2	10.2	6.6	2.1	25.4	6.6	37	67
PVM(X)1-7	0.75	1.25	1	115V/208-230V	56C	14.1	9.9	6.0	2.1	26.1	6.0	44	73	14.2	9.9	6.0	2.1	26.2	6.0	39	68
PVM(X)1-7	0.75	1.25	3	208-230V/460V	56C	14.1	10.2	6.6	2.1	26.3	6.6	44	74	14.2	10.2	6.6	2.1	26.4	6.6	39	69
PVM(X)1-8	1	1.25	1	115V/208-230V	56C	14.8	10.2	6.6	2.1	27.0	6.6	46	81	14.9	10.2	6.6	2.1	27.1	6.6	40	75
PVM(X)1-8	1	1.25	3	208-230V/460V	56C	14.8	10.4	7.2	2.1	27.3	7.2	46	99	14.9	10.4	7.2	2.1	27.4	7.2	40	93
PVM(X)1-9	1	1.25	1	115V/208-230V	56C	15.5	10.2	6.6	2.1	27.7	6.6	47	82	15.6	10.2	6.6	2.1	27.8	6.6	41	76
PVM(X)1-9	1	1.25	3	208-230V/460V	56C	15.5	10.4	7.2	2.1	28.0	7.2	47	100	15.6	10.4	7.2	2.1	28.1	7.2	41	94
PVM(X)1-10	1.5	1.15	1	115V/208-230V	56C	16.2	11.2	7.2	2.1	29.4	7.2	48	94	16.3	11.2	7.2	2.1	29.5	7.2	42	88
PVM(X)1-10	1.5	1.15	3	208-230V/460V	56C	16.2	11.2	7.2	2.1	29.4	7.2	48	90	16.3	11.2	7.2	2.1	29.5	7.2	42	84
PVM(X)1-11	1.5	1.15	1	115V/208-230V	56C	16.9	11.2	7.2	2.1	30.1	7.2	49	95	17.0	11.2	7.2	2.1	30.2	7.2	44	90
PVM(X)1-11	1.5	1.15	3	208-230V/460V	56C	16.9	11.2	7.2	2.1	30.1	7.2	49	91	17.0	11.2	7.2	2.1	30.2	7.2	44	86
PVM(X)1-12	1.5	1.15	1	115V/208-230V	56C	17.6	11.2	7.2	2.1	30.8	7.2	51	97	17.7	11.2	7.2	2.1	30.9	7.2	45	91
PVM(X)1-12	1.5	1.15	3	208-230V/460V	56C	17.6	11.2	7.2	2.1	30.8	7.2	51	93	17.7	11.2	7.2	2.1	30.9	7.2	45	87
PVM(X)1-13	1.5	1.15	1	115V/208-230V	56C	18.3	11.2	7.2	2.1	31.5	7.2	52	98	18.4	11.2	7.2	2.1	31.6	7.2	46	92
PVM(X)1-13	1.5	1.15	3	208-230V/460V	56C	18.3	11.2	7.2	2.1	31.5	7.2	52	94	18.4	11.2	7.2	2.1	31.6	7.2	46	88
PVM(X)1-15	2	1.15	1	115V/208-230V	56C	20.4	12.1	7.2	2.1	34.5	7.2	55	108	20.5	12.1	7.2	2.1	34.6	7.2	49	102
PVM(X)1-15	2	1.15	3	208-230V/460V	56C	20.4	12.1	7.2	2.1	34.5	7.2	55	104	20.5	12.1	7.2	2.1	34.6	7.2	49	98
PVM(X)1-17	2	1.15	1	115V/208-230V	56C	21.8	12.1	7.2	2.1	35.9	7.2	57	110	21.9	12.1	7.2	2.1	36.0	7.2	52	105
PVM(X)1-17	2	1.15	3	208-230V/460V	56C	21.8	12.1	7.2	2.1	35.9	7.2	57	106	21.9	12.1	7.2	2.1	36.0	7.2	52	101
PVM(X)1-19	3	1.15	1	115V/208-230V	182TC	23.7	15.4	8.9	2.6	41.7	8.9	62	150	23.3	15.4	8.9	2.6	41.3	8.9	56	144
PVM(X)1-19	3	1.15	3	208-230V/460V	182TC	23.7	13.9	8.9	2.6	40.3	8.9	62	130	23.3	13.9	8.9	2.6	39.9	8.9	56	124
PVM(X)1-21	3	1.15	1	115V/208-230V	182TC	25.1	15.4	8.9	2.6	43.1	8.9	64	152	24.7	15.4	8.9	2.6	42.7	8.9	58	146
PVM(X)1-21	3	1.15	3	208-230V/460V	182TC	25.1	13.9	8.9	2.6	41.7	8.9	64	132	24.7	13.9	8.9	2.6	41.3	8.9	58	126
PVM(X)1-23	3	1.15	1	115V/208-230V	182TC	27.3	15.4	8.9	2.6	45.3	8.9	67	155	26.1	15.4	8.9	2.6	44.1	8.9	61	149
PVM(X)1-23	3	1.15	3	208-230V/460V	182TC	27.3	13.9	8.9	2.6	43.9	8.9	67	135	26.1	13.9	8.7	2.6	42.7	8.7	61	129
PVM(X)1-25	3	1.15	1	115V/208-230V	182TC	28.7	15.4	8.9	2.6	46.7	8.9	69	157	27.6	15.4	8.7	2.6	45.6	8.7	64	152
PVM(X)1-25	3	1.15	3	208-230V/460V	182TC	28.7	13.9	8.9	2.6	45.3	8.9	69	137	27.6	13.9	8.7	2.6	44.2	8.7	64	132
PVM(X)1-27	3	1.15	3	208-230V/460V	182TC	29.5	13.9	8.9	2.6	46.1	8.9	72	140	29.2	13.9	8.7	2.6	45.8	8.7	66	134
PVM(X)1-27	3	1.15	1	115V/208-230V	182TC	29.5	15.4	8.9	2.6	47.5	8.9	72	160	29.2	15.4	8.7	2.6	47.2	8.7	66	154

PVM(X) 1

VERTICAL MULTISTAGE CENTRIFUGAL PUMPS

PUMP DIMENSIONS – STANDARD

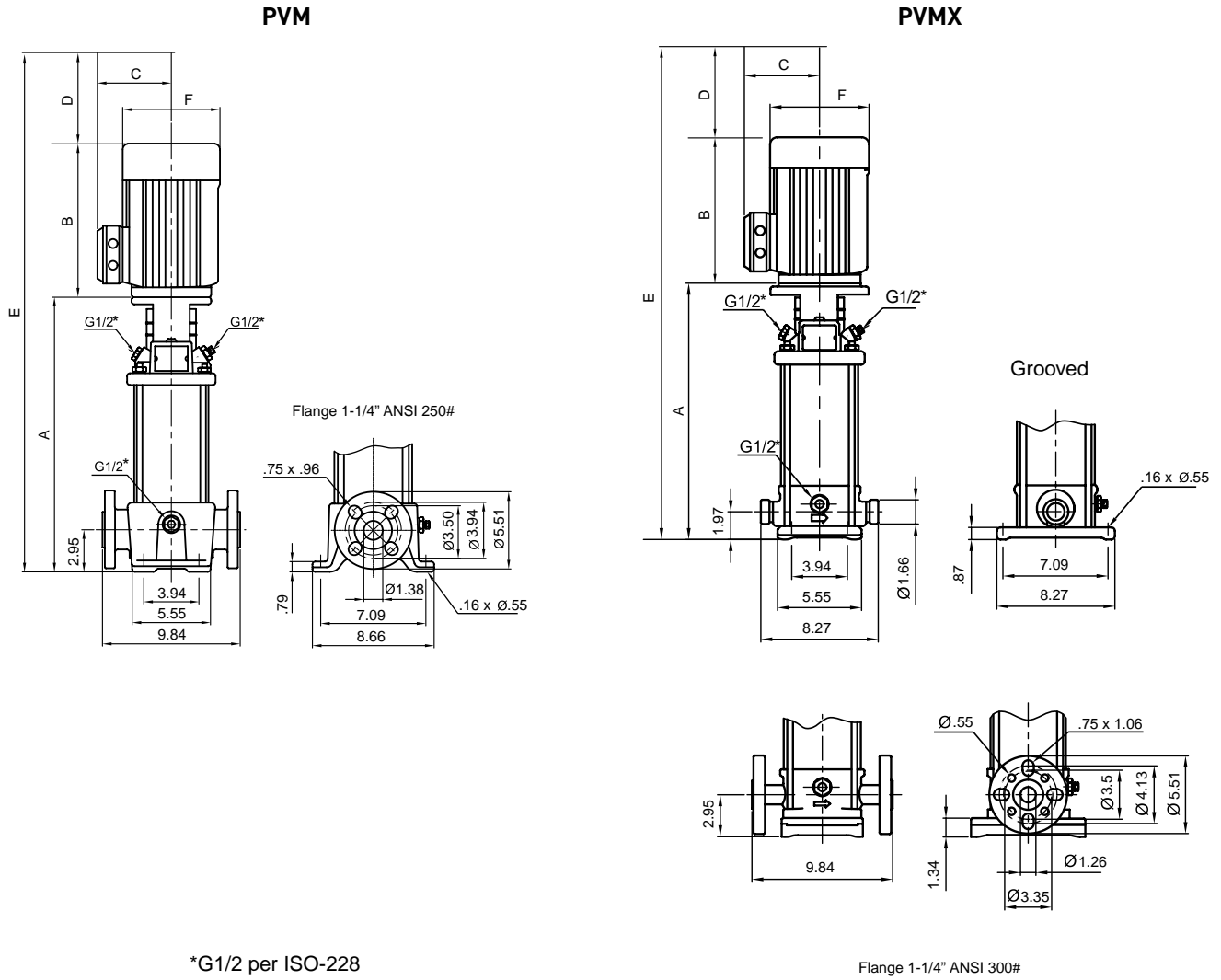

PVM(X) 1

VERTICAL MULTISTAGE CENTRIFUGAL PUMPS

PUMP DIMENSIONS – METRIC

Model Number	Motor HP	Motor Service Factor	Phase	Voltage	Motor Frame	PVM Cast Iron							PVMX Stainless Steel								
						Dimensions in mm						Weight in kgs		Dimensions in mm						Weight in kgs	
						A	B	C	D	E	F	Pump End Only	Pump & Motor	A	B	C	D	E	F	Pump End Only	Pump & Motor
PVM(X)1-2	0.5	1.25	1	115V/208-230V	56C	279	236	153	52	568	153	17	27	282	236	153	52	570	153	15	24
PVM(X)1-2	0.5	1.25	3	208-230V/460V	56C	279	258	168	52	590	168	17	33	282	258	168	52	593	168	15	30
PVM(X)1-3	0.5	1.25	1	115V/208-230V	56C	279	236	153	52	568	153	18	27	282	236	153	52	570	153	15	25
PVM(X)1-3	0.5	1.25	3	208-230V/460V	56C	279	258	168	52	590	168	18	34	282	258	168	52	593	168	15	31
PVM(X)1-4	0.5	1.25	1	115V/208-230V	56C	297	236	153	52	586	153	18	28	300	236	153	52	588	153	16	25
PVM(X)1-4	0.5	1.25	3	208-230V/460V	56C	297	258	168	52	608	168	18	34	300	258	168	52	610	168	16	32
PVM(X)1-5	0.5	1.25	1	115V/208-230V	56C	315	236	153	52	603	153	19	28	318	236	153	52	606	153	16	26
PVM(X)1-5	0.5	1.25	3	208-230V/460V	56C	315	258	168	52	626	168	19	35	318	258	168	52	628	168	16	32
PVM(X)1-6	0.75	1.25	1	115V/208-230V	56C	333	252	153	52	637	153	19	33	335	252	153	52	639	153	17	30
PVM(X)1-6	0.75	1.25	3	208-230V/460V	56C	333	258	168	52	643	168	19	33	335	258	168	52	646	168	17	30
PVM(X)1-7	0.75	1.25	1	115V/208-230V	56C	358	252	153	52	662	153	20	33	361	252	153	52	665	153	17	31
PVM(X)1-7	0.75	1.25	3	208-230V/460V	56C	358	258	168	52	669	168	20	34	361	258	168	52	671	168	17	31
PVM(X)1-8	1	1.25	1	115V/208-230V	56C	376	258	168	52	686	168	21	37	378	258	168	52	689	168	18	34
PVM(X)1-8	1	1.25	3	208-230V/460V	56C	376	264	183	52	693	183	21	45	378	264	183	52	695	183	18	42
PVM(X)1-9	1	1.25	1	115V/208-230V	56C	394	258	168	52	704	168	21	37	396	258	168	52	707	168	19	35
PVM(X)1-9	1	1.25	3	208-230V/460V	56C	394	264	183	52	711	183	21	45	396	264	183	52	713	183	19	43
PVM(X)1-10	1.5	1.15	1	115V/208-230V	56C	411	283	182	52	747	182	22	43	414	283	182	52	750	182	19	40
PVM(X)1-10	1.5	1.15	3	208-230V/460V	56C	411	284	183	52	748	183	22	41	414	284	183	52	750	183	19	38
PVM(X)1-11	1.5	1.15	1	115V/208-230V	56C	429	283	182	52	765	182	22	43	432	283	182	52	768	182	20	41
PVM(X)1-11	1.5	1.15	3	208-230V/460V	56C	429	284	183	52	765	183	22	41	432	284	183	52	768	183	20	39
PVM(X)1-12	1.5	1.15	1	115V/208-230V	56C	447	283	182	52	783	182	23	44	450	283	182	52	785	182	20	41
PVM(X)1-12	1.5	1.15	3	208-230V/460V	56C	447	284	183	52	783	183	23	42	450	284	183	52	786	183	20	39
PVM(X)1-13	1.5	1.15	1	115V/208-230V	56C	465	283	182	52	801	182	24	44	467	283	182	52	803	182	21	42
PVM(X)1-13	1.5	1.15	3	208-230V/460V	56C	465	284	183	52	801	183	24	43	467	284	183	52	803	183	21	40
PVM(X)1-15	2	1.15	1	115V/208-230V	56C	518	306	182	52	877	182	25	49	521	306	182	52	879	182	22	46
PVM(X)1-15	2	1.15	3	208-230V/460V	56C	518	306	183	52	877	183	25	47	521	306	183	52	879	183	22	44
PVM(X)1-17	2	1.15	1	115V/208-230V	56C	554	306	182	52	912	182	26	50	556	306	182	52	915	182	23	47
PVM(X)1-17	2	1.15	3	208-230V/460V	56C	554	306	183	52	912	183	26	48	556	306	183	52	915	183	23	46
PVM(X)1-19	3	1.15	1	115V/208-230V	182TC	602	392	225	67	1060	225	28	68	592	392	225	67	1050	225	25	65
PVM(X)1-19	3	1.15	3	208-230V/460V	182TC	602	354	225	67	1022	225	28	59	592	354	225	67	1012	225	25	56
PVM(X)1-21	3	1.15	1	115V/208-230V	182TC	638	392	225	67	1096	225	29	69	627	392	225	67	1086	225	26	66
PVM(X)1-21	3	1.15	3	208-230V/460V	182TC	638	354	225	67	1058	225	29	60	627	354	225	67	1048	225	26	57
PVM(X)1-23	3	1.15	1	115V/208-230V	182TC	693	392	225	67	1152	225	30	70	663	392	225	67	1121	225	28	68
PVM(X)1-23	3	1.15	3	208-230V/460V	182TC	693	354	225	67	1114	225	30	61	663	354	220	67	1083	220	28	59
PVM(X)1-25	3	1.15	1	115V/208-230V	182TC	729	392	225	67	1187	225	31	71	701	392	220	67	1159	220	29	69
PVM(X)1-25	3	1.15	3	208-230V/460V	182TC	729	354	225	67	1149	225	31	62	701	354	220	67	1122	220	29	60
PVM(X)1-27	3	1.15	3	208-230V/460V	182TC	749	354	225	67	1170	225	33	63	742	354	220	67	1162	220	30	61
PVM(X)1-27	3	1.15	1	115V/208-230V	182TC	749	392	225	67	1208	225	33	73	742	392	220	67	1200	220	30	70

PVM(X) 1

VERTICAL MULTISTAGE CENTRIFUGAL PUMPS

PUMP DIMENSIONS - METRIC

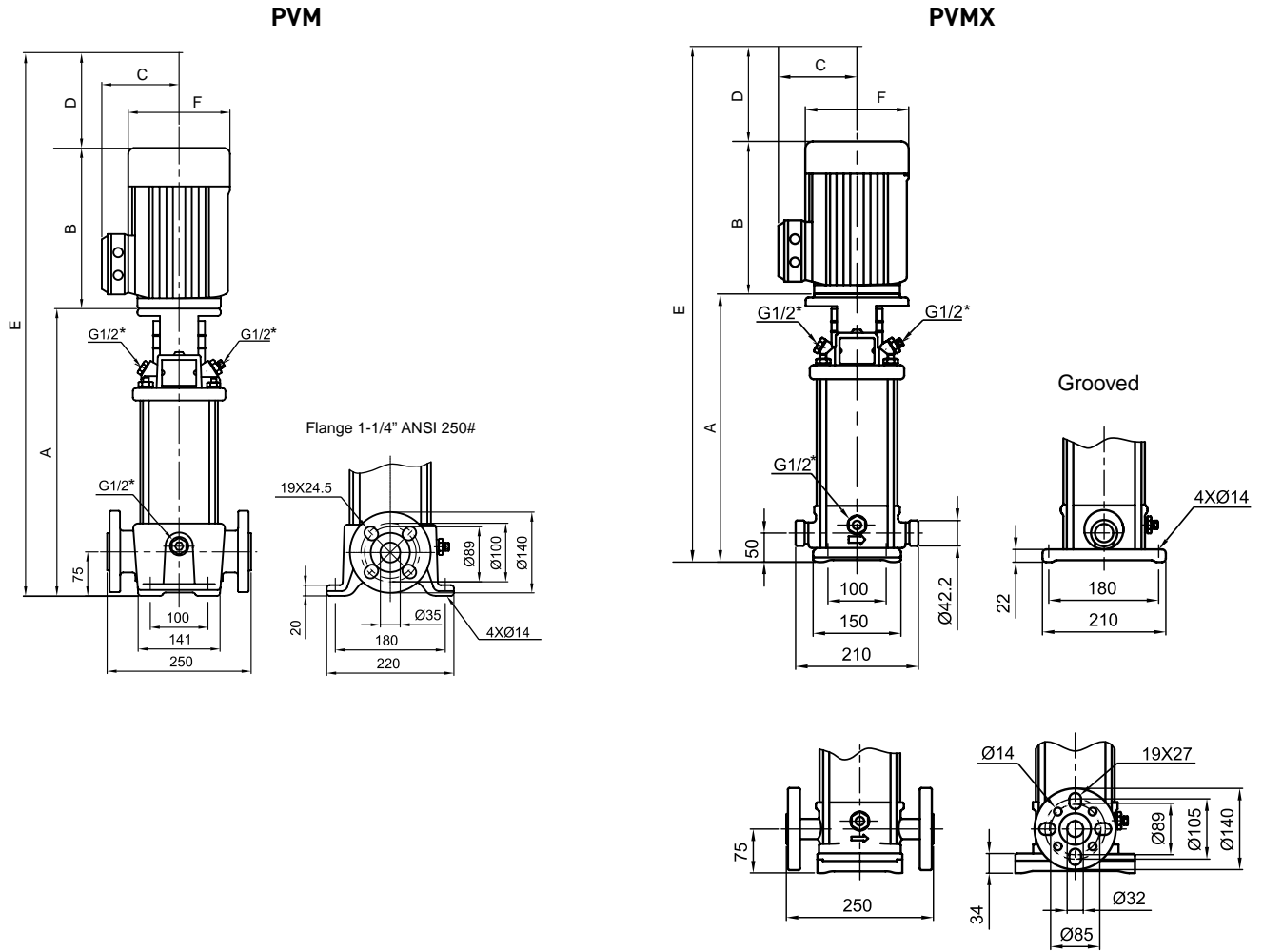

*G1/2 per ISO-228

Flange 1-1/4" ANSI 300#

PVM(X) 1

VERTICAL MULTISTAGE CENTRIFUGAL PUMPS

HYDRAULIC PERFORMANCE

Curve: PVM(X) 1
Date: 10/01/14

Nominal RPM: **3500**
Based on Fresh Water@ **68 deg. F**
Maximum Working Pressure: **360 PSI**

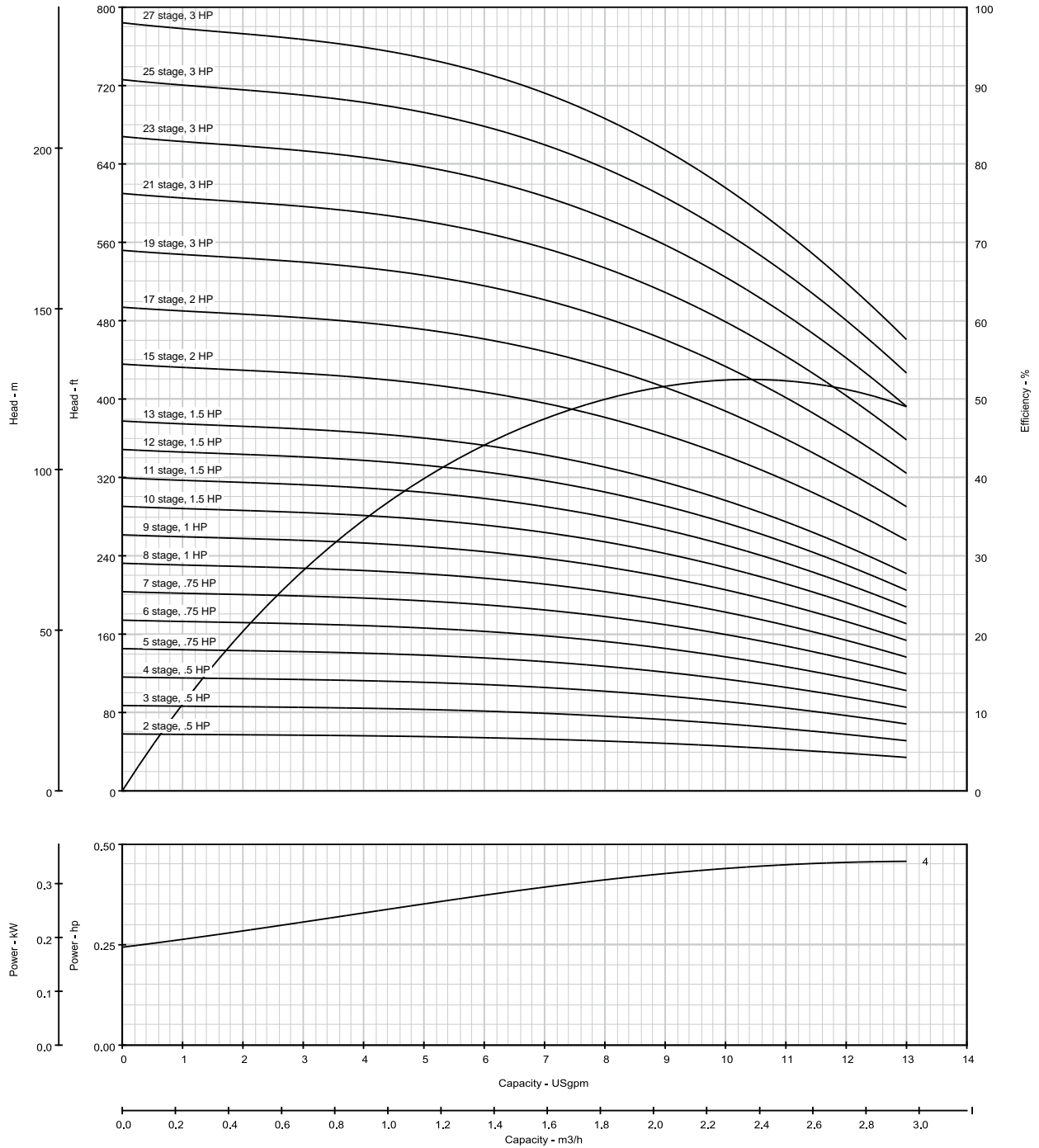

THIS PAGE INTENTIONALLY LEFT BLANK

PVM(X) 3

VERTICAL MULTISTAGE CENTRIFUGAL PUMPS

PUMP DIMENSIONS – STANDARD

Model Number	Motor HP	Motor Service Factor	Phase	Voltage	Motor Frame	PVM Cast Iron							PVMX Stainless Steel								
						Dimensions in inches						Weight in Lbs		Dimensions in inches						Weight in Lbs	
						A	B	C	D	E	F	Pump End Only	Pump & Motor	A	B	C	D	E	F	Pump End Only	Pump & Motor
PVM(X)3-2	0.5	1.25	1	115V/208-230V	56C	11.0	9.3	6.0	2.1	22.4	6.0	38	59	11.1	9.3	6.0	2.1	22.5	6.0	32	53
PVM(X)3-2	0.5	1.25	3	208-230V/460V	56C	11.0	10.2	6.6	2.1	23.2	6.6	38	73	11.1	10.2	6.6	2.1	23.3	6.6	32	67
PVM(X)3-3	0.5	1.25	1	115V/208-230V	56C	11.0	9.3	6.0	2.1	22.4	6.0	39	60	11.1	9.3	6.0	2.1	22.5	6.0	33	54
PVM(X)3-3	0.5	1.25	3	208-230V/460V	56C	11.0	10.2	6.6	2.1	23.2	6.6	39	74	11.1	10.2	6.6	2.1	23.3	6.6	33	68
PVM(X)3-4	0.75	1.25	1	115V/208-230V	56C	11.7	9.9	6.0	2.1	23.7	6.0	40	69	11.8	9.9	6.0	2.1	23.8	6.0	35	64
PVM(X)3-4	0.75	1.25	3	208-230V/460V	56C	11.7	10.2	6.6	2.1	23.9	6.6	40	70	11.8	10.2	6.6	2.1	24.0	6.6	35	65
PVM(X)3-5	1	1.25	1	115V/208-230V	56C	12.6	10.2	6.6	2.1	24.8	6.6	42	77	12.8	10.2	6.6	2.1	25.0	6.6	36	71
PVM(X)3-5	1	1.25	3	208-230V/460V	56C	12.6	10.4	7.2	2.1	25.1	7.2	42	95	12.8	10.4	7.2	2.1	25.3	7.2	36	89
PVM(X)3-6	1	1.25	1	115V/208-230V	56C	13.3	10.2	6.6	2.1	25.5	6.6	43	78	13.5	10.2	6.6	2.1	25.7	6.6	37	72
PVM(X)3-6	1	1.25	3	208-230V/460V	56C	13.3	10.4	7.2	2.1	25.8	7.2	43	96	13.5	10.4	7.2	2.1	26.0	7.2	37	90
PVM(X)3-7	1.5	1.15	1	115V/208-230V	56C	14.0	11.2	7.2	2.1	27.2	7.2	44	90	14.2	11.2	7.2	2.1	27.4	7.2	39	85
PVM(X)3-7	1.5	1.15	3	208-230V/460V	56C	14.0	11.2	7.2	2.1	27.2	7.2	44	86	14.2	11.2	7.2	2.1	27.4	7.2	39	81
PVM(X)3-8	1.5	1.15	1	115V/208-230V	56C	14.8	11.2	7.2	2.1	28.0	7.2	46	92	14.9	11.2	7.2	2.1	28.1	7.2	40	86
PVM(X)3-8	1.5	1.15	3	208-230V/460V	56C	14.8	11.2	7.2	2.1	28.0	7.2	46	88	14.9	11.2	7.2	2.1	28.1	7.2	40	82
PVM(X)3-9	1.5	1.15	1	115V/208-230V	56C	16.1	11.2	7.2	2.1	29.3	7.2	47	93	16.2	11.2	7.2	2.1	29.4	7.2	41	87
PVM(X)3-9	1.5	1.15	3	208-230V/460V	56C	16.1	11.2	7.2	2.1	29.3	7.2	47	89	16.2	11.2	7.2	2.1	29.4	7.2	41	83
PVM(X)3-10	2	1.15	1	115V/208-230V	56C	16.8	12.1	7.2	2.1	30.9	7.2	48	101	16.9	12.1	7.2	2.1	31.0	7.2	42	95
PVM(X)3-10	2	1.15	3	208-230V/460V	56C	16.8	12.1	7.2	2.1	30.9	7.2	48	97	16.9	12.1	7.2	2.1	31.0	7.2	42	91
PVM(X)3-11	2	1.15	1	115V/208-230V	56C	17.5	12.1	7.2	2.1	31.6	7.2	49	102	17.6	12.1	7.2	2.1	31.7	7.2	44	97
PVM(X)3-11	2	1.15	3	208-230V/460V	56C	17.5	12.1	7.2	2.1	31.6	7.2	49	98	17.6	12.1	7.2	2.1	31.7	7.2	44	93
PVM(X)3-12	2	1.15	1	115V/208-230V	56C	18.2	12.1	7.2	2.1	32.3	7.2	51	104	18.3	12.1	7.2	2.1	32.4	7.2	45	98
PVM(X)3-12	2	1.15	3	208-230V/460V	56C	18.2	12.1	7.2	2.1	32.3	7.2	51	100	18.3	12.1	7.2	2.1	32.4	7.2	45	94
PVM(X)3-13	3	1.15	1	115V/208-230V	182TC	19.4	15.4	8.9	2.6	37.4	8.9	54	142	19.6	15.4	8.7	2.6	37.6	8.7	48	136
PVM(X)3-13	3	1.15	3	208-230V/460V	182TC	19.4	13.9	8.9	2.6	36.0	8.9	54	122	19.6	13.9	8.7	2.6	36.2	8.7	48	116
PVM(X)3-15	3	1.15	1	115V/208-230V	182TC	20.9	15.4	8.9	2.6	38.9	8.9	56	144	21.0	15.4	8.7	2.6	39.0	8.7	51	139
PVM(X)3-15	3	1.15	3	208-230V/460V	182TC	20.9	13.9	8.9	2.6	37.5	8.9	56	124	21.0	13.9	8.7	2.6	37.6	8.7	51	119
PVM(X)3-17	3	1.15	1	115V/208-230V	182TC	22.3	15.4	8.9	2.6	40.3	8.9	59	147	22.9	15.4	8.7	2.6	40.9	8.7	53	141
PVM(X)3-17	3	1.15	3	208-230V/460V	182TC	22.3	13.9	8.9	2.6	38.9	8.9	59	127	22.9	13.9	8.7	2.6	39.5	8.7	53	121
PVM(X)3-19	5	1.15	1	208-230V	213TC	24.3	15.5	9.6	3.1	42.9	9.6	62	179	24.5	15.5	9.6	3.1	43.1	9.6	56	173
PVM(X)3-19	5	1.15	3	208-230V/460V	184TC	24.3	13.9	8.9	2.6	40.9	8.9	62	130	24.5	13.9	8.9	2.6	41.1	8.9	56	124
PVM(X)3-21	5	1.15	1	208-230V	213TC	25.8	15.5	9.6	3.1	44.4	9.6	64	181	25.9	15.5	9.6	3.1	44.5	9.6	58	175
PVM(X)3-21	5	1.15	3	208-230V/460V	184TC	25.8	13.9	8.9	2.6	42.4	8.9	64	132	25.9	13.9	8.9	2.6	42.5	8.9	58	126
PVM(X)3-23	5	1.15	1	208-230V	213TC	27.2	15.5	9.6	3.1	45.8	9.6	67	184	27.3	15.5	9.6	3.1	45.9	9.6	61	178
PVM(X)3-23	5	1.15	3	208-230V/460V	184TC	27.2	13.9	8.9	2.6	43.8	8.9	67	135	27.3	13.9	8.9	2.6	43.9	8.9	61	129
PVM(X)3-25	5	1.15	1	208-230V	213TC	28.1	15.5	9.6	3.1	46.7	9.6	69	186	27.8	15.5	9.6	3.1	46.4	9.6	64	181
PVM(X)3-25	5	1.15	3	208-230V/460V	184TC	28.1	13.9	8.9	2.6	44.7	8.9	69	137	27.8	13.9	8.9	2.6	44.4	8.9	64	132

PVM(X) 3 VERTICAL MULTISTAGE CENTRIFUGAL PUMPS

PUMP DIMENSIONS - STANDARD

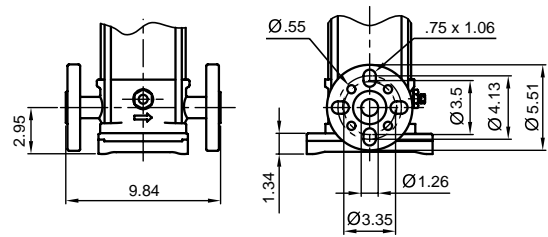
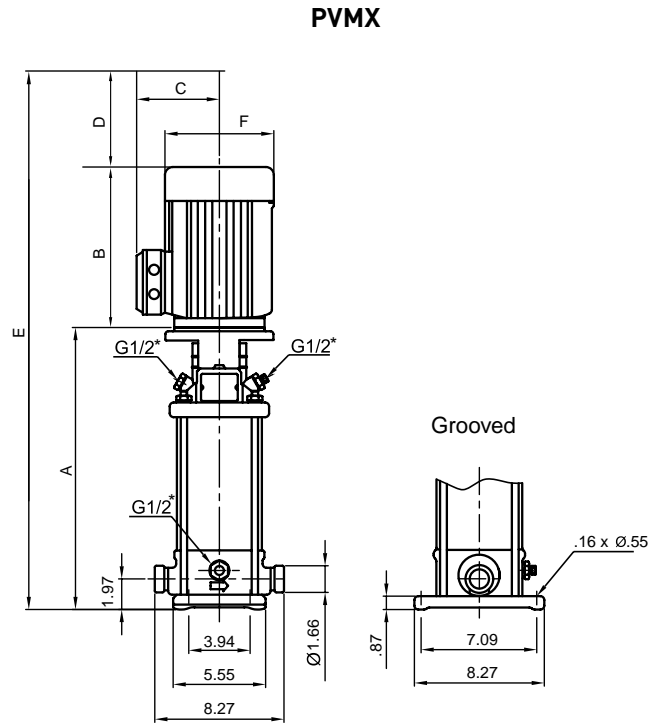
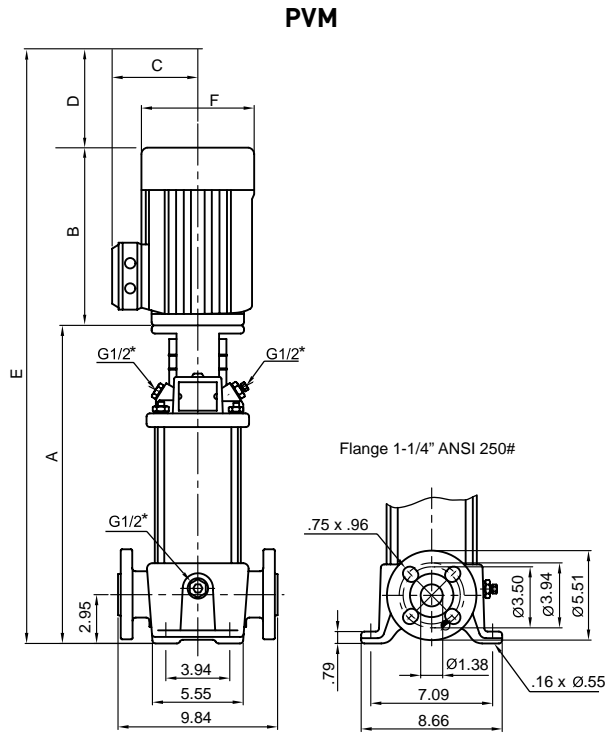

Flange 1-1/4" ANSI 300#

PVM(X) 3

VERTICAL MULTISTAGE CENTRIFUGAL PUMPS

PUMP DIMENSIONS – METRIC

Model Number	Motor HP	Motor Service Factor	Phase	Voltage	Motor Frame	PVM Cast Iron							PVMX Stainless Steel								
						Dimensions in mm						Weight in kgs		Dimensions in mm						Weight in kgs	
						A	B	C	D	E	F	Pump End Only	Pump & Motor	A	B	C	D	E	F	Pump End Only	Pump & Motor
PVM(X)3-2	0.5	1.25	1	115V/208-230V	56C	279	236	153	52	568	153	17	27	282	236	153	52	570	153	15	24
PVM(X)3-2	0.5	1.25	3	208-230V/460V	56C	279	258	168	52	590	168	17	33	282	258	168	52	593	168	15	30
PVM(X)3-3	0.5	1.25	1	115V/208-230V	56C	279	236	153	52	568	153	18	27	282	236	153	52	570	153	15	25
PVM(X)3-3	0.5	1.25	3	208-230V/460V	56C	279	258	168	52	590	168	18	34	282	258	168	52	593	168	15	31
PVM(X)3-4	0.75	1.25	1	115V/208-230V	56C	297	252	153	52	601	153	18	31	300	252	153	52	604	153	16	29
PVM(X)3-4	0.75	1.25	3	208-230V/460V	56C	297	258	168	52	608	168	18	32	300	258	168	52	610	168	16	29
PVM(X)3-5	1	1.25	1	115V/208-230V	56C	320	258	168	52	631	168	19	35	325	258	168	52	636	168	16	32
PVM(X)3-5	1	1.25	3	208-230V/460V	56C	320	264	183	52	637	183	19	43	325	264	183	52	642	183	16	40
PVM(X)3-6	1	1.25	1	115V/208-230V	56C	338	258	168	52	648	168	19	35	343	258	168	52	653	168	17	33
PVM(X)3-6	1	1.25	3	208-230V/460V	56C	338	264	183	52	655	183	19	43	343	264	183	52	660	183	17	41
PVM(X)3-7	1.5	1.15	1	115V/208-230V	56C	356	283	182	52	691	182	20	41	361	283	182	52	697	182	17	38
PVM(X)3-7	1.5	1.15	3	208-230V/460V	56C	356	284	183	52	692	183	20	39	361	284	183	52	697	183	17	37
PVM(X)3-8	1.5	1.15	1	115V/208-230V	56C	376	283	182	52	712	182	21	41	378	283	182	52	714	182	18	39
PVM(X)3-8	1.5	1.15	3	208-230V/460V	56C	376	284	183	52	712	183	21	40	378	284	183	52	715	183	18	37
PVM(X)3-9	1.5	1.15	1	115V/208-230V	56C	409	283	182	52	745	182	21	42	411	283	182	52	747	182	19	40
PVM(X)3-9	1.5	1.15	3	208-230V/460V	56C	409	284	183	52	745	183	21	40	411	284	183	52	748	183	19	38
PVM(X)3-10	2	1.15	1	115V/208-230V	56C	427	306	182	52	785	182	22	46	429	306	182	52	788	182	19	43
PVM(X)3-10	2	1.15	3	208-230V/460V	56C	427	306	183	52	785	183	22	44	429	306	183	52	788	183	19	41
PVM(X)3-11	2	1.15	1	115V/208-230V	56C	445	306	182	52	803	182	22	46	447	306	182	52	806	182	20	44
PVM(X)3-11	2	1.15	3	208-230V/460V	56C	445	306	183	52	803	183	22	45	447	306	183	52	806	183	20	42
PVM(X)3-12	2	1.15	1	115V/208-230V	56C	462	306	182	52	821	182	23	47	465	306	182	52	823	182	20	44
PVM(X)3-12	2	1.15	3	208-230V/460V	56C	462	306	183	52	821	183	23	45	465	306	183	52	823	183	20	43
PVM(X)3-13	3	1.15	1	115V/208-230V	182TC	493	392	225	67	951	225	24	64	498	392	220	67	956	220	22	62
PVM(X)3-13	3	1.15	3	208-230V/460V	182TC	493	354	225	67	913	225	24	55	498	354	220	67	918	220	22	53
PVM(X)3-15	3	1.15	1	115V/208-230V	182TC	531	392	225	67	989	225	26	65	533	392	220	67	992	220	23	63
PVM(X)3-15	3	1.15	3	208-230V/460V	182TC	531	354	225	67	951	225	26	56	533	354	220	67	954	220	23	54
PVM(X)3-17	3	1.15	1	115V/208-230V	182TC	566	392	225	67	1025	225	27	67	582	392	220	67	1040	220	24	64
PVM(X)3-17	3	1.15	3	208-230V/460V	182TC	566	354	225	67	987	225	27	58	582	354	220	67	1002	220	24	55
PVM(X)3-19	5	1.15	1	208-230V	213TC	617	394	243	79	1090	243	28	81	622	394	243	79	1095	243	25	78
PVM(X)3-19	5	1.15	3	208-230V/460V	184TC	617	354	225	67	1038	225	28	59	622	354	225	67	1043	225	25	56
PVM(X)3-21	5	1.15	1	208-230V	213TC	655	394	243	79	1128	243	29	82	658	394	243	79	1131	243	26	80
PVM(X)3-21	5	1.15	3	208-230V/460V	184TC	655	354	225	67	1076	225	29	60	658	354	225	67	1078	225	26	57
PVM(X)3-23	5	1.15	1	208-230V	213TC	691	394	243	79	1164	243	30	83	693	394	243	79	1166	243	28	81
PVM(X)3-23	5	1.15	3	208-230V/460V	184TC	691	354	225	67	1111	225	30	61	693	354	225	67	1114	225	28	59
PVM(X)3-25	5	1.15	1	208-230V	213TC	714	394	243	79	1187	243	31	84	706	394	243	79	1179	243	29	82
PVM(X)3-25	5	1.15	3	208-230V/460V	184TC	714	354	226	67	1134	226	31	62	706	354	225	67	1127	225	29	60

PVM(X) 3 VERTICAL MULTISTAGE CENTRIFUGAL PUMPS

PUMP DIMENSIONS - METRIC

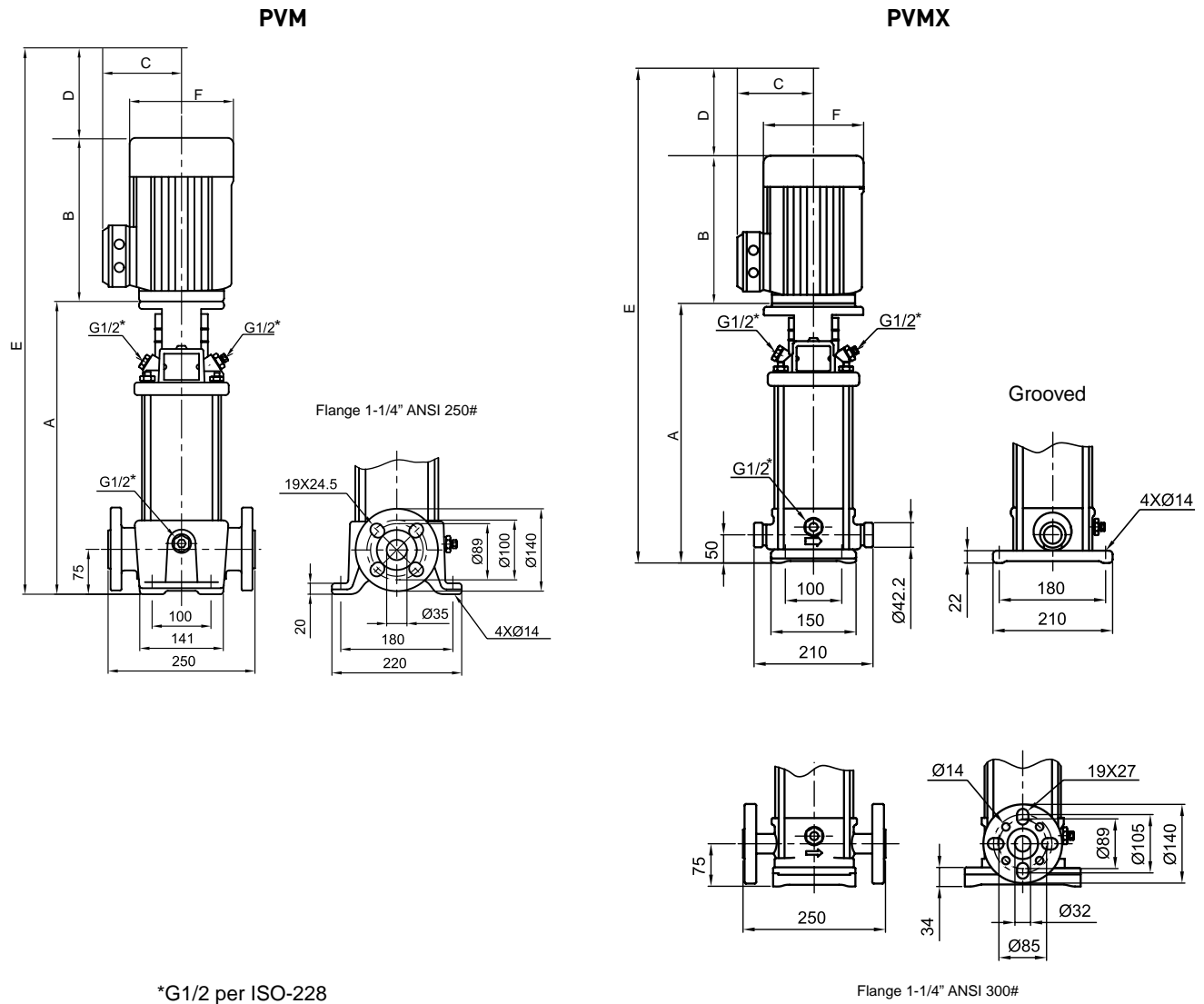

PVM(X) 3

VERTICAL MULTISTAGE CENTRIFUGAL PUMPS

HYDRAULIC PERFORMANCE

Curve PVM(X) 3
Date 10/01/14

Nominal RPM: **3500**
Based on Fresh Water@ **68 deg. F**
Maximum Working Pressure: **360 PSI**

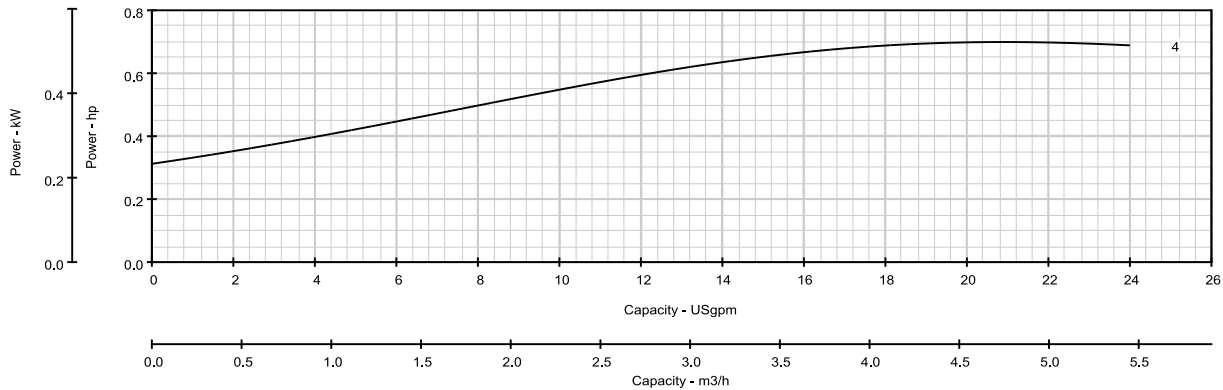
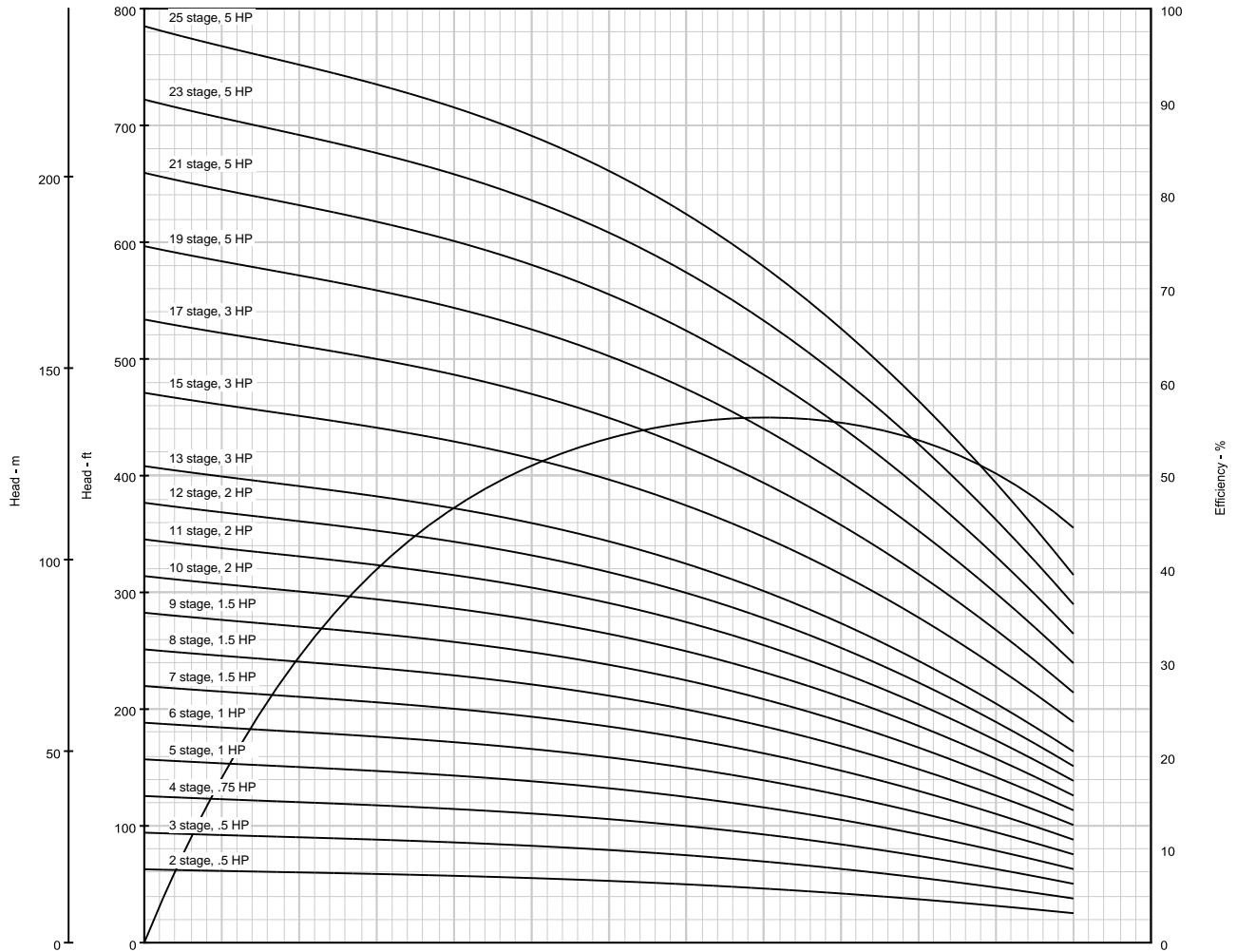

THIS PAGE INTENTIONALLY LEFT BLANK

PVM(X) 5

VERTICAL MULTISTAGE CENTRIFUGAL PUMPS

PUMP DIMENSIONS – STANDARD

Model Number	Motor HP	Motor Service Factor	Phase	Voltage	Motor Frame	PVM Cast Iron							PVMX Stainless Steel								
						Dimensions in inches						Weight in Lbs		Dimensions in inches						Weight in Lbs	
						A	B	C	D	E	F	Pump End Only	Pump & Motor	A	B	C	D	E	F	Pump End Only	Pump & Motor
PVM(X)5-2	0.75	1.25	1	115V/208-230V	56C	11.0	9.9	6.0	2.1	23.0	6.0	38	67	11.1	9.9	6.0	2.1	23.1	6.0	32	61
PVM(X)5-2	0.75	1.25	3	208-230V/460V	56C	11.0	10.2	6.6	2.1	23.2	6.6	38	68	11.1	10.2	6.6	2.1	23.3	6.6	32	62
PVM(X)5-3	1	1.25	1	115V/208-230V	56C	12.3	10.2	6.6	2.1	24.5	6.6	39	74	12.4	10.2	6.6	2.1	24.6	6.6	33	68
PVM(X)5-3	1	1.25	3	208-230V/460V	56C	12.3	10.4	7.2	2.1	24.8	7.2	39	92	12.4	10.4	7.2	2.1	24.9	7.2	33	86
PVM(X)5-4	1.5	1.15	1	115V/208-230V	56C	13.3	11.2	7.2	2.1	26.5	7.2	40	86	13.5	11.2	7.2	2.1	26.7	7.2	35	81
PVM(X)5-4	1.5	1.15	3	208-230V/460V	56C	13.3	11.2	7.2	2.1	26.5	7.2	40	82	13.5	11.2	7.2	2.1	26.7	7.2	35	77
PVM(X)5-5	2	1.15	1	115V/208-230V	56C	15.0	12.1	7.2	2.1	29.1	7.2	42	95	15.2	12.1	7.2	2.1	29.3	7.2	36	89
PVM(X)5-5	2	1.15	3	208-230V/460V	56C	15.0	12.1	7.2	2.1	29.1	7.2	42	91	15.2	12.1	7.2	2.1	29.3	7.2	36	85
PVM(X)5-6	2	1.15	1	115V/208-230V	56C	16.1	12.1	7.2	2.1	30.2	7.2	43	96	16.2	12.1	7.2	2.1	30.3	7.2	37	90
PVM(X)5-6	2	1.15	3	208-230V/460V	56C	16.1	12.1	7.2	2.1	30.2	7.2	43	92	16.2	12.1	7.2	2.1	30.3	7.2	37	86
PVM(X)5-7	3	1.15	1	115V/208-230V	182TC	17.7	15.4	8.9	2.6	35.7	8.9	46	134	17.8	15.4	8.7	2.6	35.8	8.7	40	128
PVM(X)5-7	3	1.15	3	208-230V/460V	182TC	17.7	13.9	8.9	2.6	34.3	8.9	46	114	17.8	13.9	8.7	2.6	34.4	8.7	40	108
PVM(X)5-8	3	1.15	1	115V/208-230V	182TC	18.7	15.4	8.9	2.6	36.7	8.9	47	135	18.8	15.4	8.7	2.6	36.8	8.7	42	130
PVM(X)5-8	3	1.15	3	208-230V/460V	182TC	18.7	13.9	8.9	2.6	35.3	8.9	47	115	18.8	13.9	8.7	2.6	35.4	8.7	42	110
PVM(X)5-9	3	1.15	1	115V/208-230V	182TC	19.8	15.4	8.9	2.6	37.8	8.9	49	137	19.9	15.4	8.7	2.6	37.9	8.7	43	131
PVM(X)5-9	3	1.15	3	208-230V/460V	182TC	19.8	13.9	8.9	2.6	36.4	8.9	49	117	19.9	13.9	8.7	2.6	36.5	8.7	43	111
PVM(X)5-10	5	1.15	1	208-230V	213TC	21.0	15.5	9.6	3.1	39.6	9.6	50	167	21.2	15.5	9.6	3.1	39.8	9.6	44	161
PVM(X)5-10	5	1.15	3	208-230V/460V	184TC	21.0	13.9	8.9	2.6	37.6	8.9	50	118	21.2	13.9	8.9	2.6	37.8	8.9	44	112
PVM(X)5-11	5	1.15	1	208-230V	213TC	22.1	15.5	9.6	3.1	40.7	9.6	51	168	22.2	15.5	9.6	3.1	40.8	9.6	45	162
PVM(X)5-11	5	1.15	3	208-230V/460V	184TC	22.1	13.9	8.9	2.6	38.7	8.9	51	119	22.2	13.9	8.9	2.6	38.8	8.9	45	113
PVM(X)5-12	5	1.15	1	208-230V	213TC	23.1	15.5	9.6	3.1	41.7	9.6	52	169	23.3	15.5	9.6	3.1	41.9	9.6	47	164
PVM(X)5-12	5	1.15	3	208-230V/460V	184TC	23.1	13.9	8.9	2.6	39.7	8.9	52	120	23.3	13.9	8.9	2.6	39.9	8.9	47	115
PVM(X)5-13	5	1.15	1	208-230V	213TC	24.2	15.5	9.6	3.1	42.8	9.6	54	171	24.4	15.5	9.6	3.1	43.0	9.6	48	165
PVM(X)5-13	5	1.15	3	208-230V/460V	184TC	24.2	13.9	8.9	2.6	40.8	8.9	54	122	24.4	13.9	8.9	2.6	41.0	8.9	48	116
PVM(X)5-14	5	1.15	1	208-230V	213TC	25.3	15.5	9.6	3.1	43.9	9.6	55	172	25.4	15.5	9.6	3.1	44.0	9.6	49	166
PVM(X)5-14	5	1.15	3	208-230V/460V	184TC	25.3	13.9	8.9	2.6	41.9	8.9	55	123	25.4	13.9	8.9	2.6	42.0	8.9	49	117
PVM(X)5-15	5	1.15	1	208-230V	213TC	26.3	15.5	9.6	3.1	44.9	9.6	56	173	26.5	15.5	9.6	3.1	45.1	9.6	51	168
PVM(X)5-15	5	1.15	3	208-230V/460V	184TC	26.3	13.9	8.9	2.6	42.9	8.9	56	124	26.5	13.9	8.9	2.6	43.1	8.9	51	119
PVM(X)5-16	5	1.15	1	208-230V	213TC	27.4	15.5	9.6	3.1	46.0	9.6	58	175	27.5	15.5	9.6	3.1	46.1	9.6	52	169
PVM(X)5-16	5	1.15	3	208-230V/460V	184TC	27.4	13.9	8.9	2.6	44.0	8.9	58	126	27.5	13.9	8.9	2.6	44.1	8.9	52	120
PVM(X)5-18	7.5	1.15	1	208-230V	213TC	29.4	15.5	8.7	3.1	48.0	8.7	60	177	29.4	15.5	8.7	3.1	48.0	8.7	55	172
PVM(X)5-18	7.5	1.15	3	208-230V/460V	213TC	29.4	15.5	9.6	3.1	48.1	9.6	60	158	29.4	15.5	9.6	3.1	48.1	9.6	55	153
PVM(X)5-20	7.5	1.15	1	208-230V	213TC	31.5	15.5	8.7	3.1	50.1	8.7	63	180	31.6	15.5	8.7	3.1	50.2	8.7	57	174
PVM(X)5-20	7.5	1.15	3	208-230V/460V	213TC	21.5	15.5	9.6	3.1	40.2	9.6	63	161	31.6	15.5	9.6	3.1	50.3	9.6	57	155
PVM(X)5-22	7.5	1.15	1	208-230V	213TC	33.6	15.5	8.7	3.1	52.2	8.7	65	182	33.8	15.5	8.7	3.1	52.4	8.7	60	177
PVM(X)5-22	7.5	1.15	3	208-230V/460V	213TC	33.6	15.5	9.6	3.1	52.3	9.6	65	163	33.8	15.5	9.6	3.1	52.5	9.6	60	158
PVM(X)5-24	7.5	1.15	1	208-230V	213TC	35.7	15.5	8.7	3.1	54.3	8.7	68	185	35.9	15.5	8.7	3.1	54.5	8.7	62	179
PVM(X)5-24	7.5	1.15	3	208-230V/460V	213TC	35.7	15.5	9.6	3.1	54.4	9.6	68	166	35.9	15.5	9.6	3.1	54.6	9.6	62	160

PVM(X) 5 VERTICAL MULTISTAGE CENTRIFUGAL PUMPS

PUMP DIMENSIONS – STANDARD

PVM

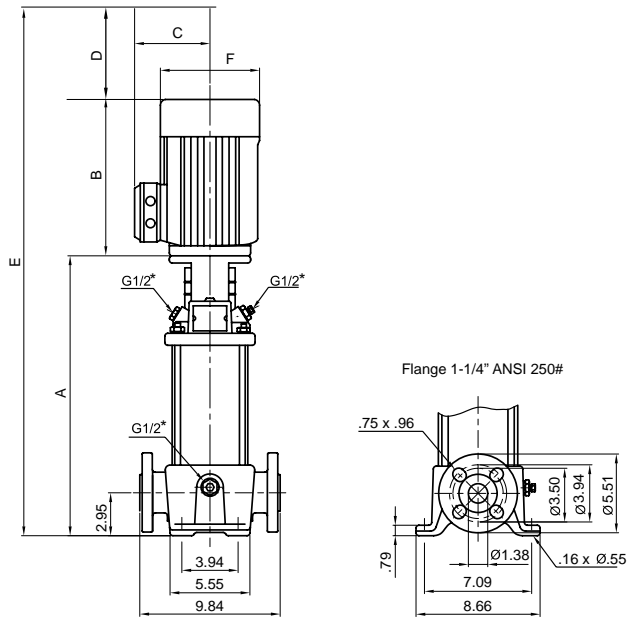

*G1/2 per ISO-228

PVMX

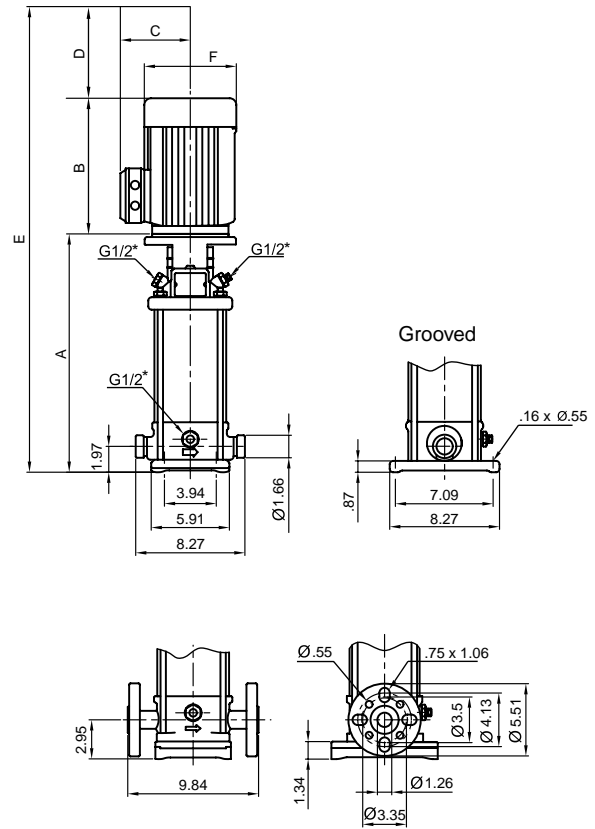

Flange 1-1/4" ANSI 300#

PVM(X) 5

VERTICAL MULTISTAGE CENTRIFUGAL PUMPS

PUMP DIMENSIONS – METRIC

Model Number	Motor HP	Motor Service Factor	Phase	Voltage	Motor Frame	PVM Cast Iron							PVMX Stainless Steel								
						Dimensions in mm						Weight in kgs		Dimensions in mm						Weight in kgs	
						A	B	C	D	E	F	Pump End Only	Pump & Motor	A	B	C	D	E	F	Pump End Only	Pump & Motor
PVM(X)5-2	0.75	1.25	1	115V/208-230V	56C	279	252	153	52	584	153	17	30	282	252	153	52	586	153	15	28
PVM(X)5-2	0.75	1.25	3	208-230V/460V	56C	279	258	168	52	590	168	17	31	282	258	168	52	593	168	15	28
PVM(X)5-3	1	1.25	1	115V/208-230V	56C	312	258	168	52	623	168	18	34	315	258	168	52	625	168	15	31
PVM(X)5-3	1	1.25	3	208-230V/460V	56C	312	264	183	52	629	183	18	42	315	264	183	52	632	183	15	39
PVM(X)5-4	1.5	1.15	1	115V/208-230V	56C	338	283	182	52	674	182	18	39	343	283	182	52	679	182	16	37
PVM(X)5-4	1.5	1.15	3	208-230V/460V	56C	338	284	183	52	674	183	18	37	343	284	183	52	679	183	16	35
PVM(X)5-5	2	1.15	1	115V/208-230V	56C	381	306	182	52	739	182	19	43	386	306	182	52	745	182	16	40
PVM(X)5-5	2	1.15	3	208-230V/460V	56C	381	306	183	52	739	183	19	41	386	306	183	52	745	183	16	39
PVM(X)5-6	2	1.15	1	115V/208-230V	56C	409	306	182	52	767	182	19	43	411	306	182	52	770	182	17	41
PVM(X)5-6	2	1.15	3	208-230V/460V	56C	409	306	183	52	767	183	19	42	411	306	183	52	770	183	17	39
PVM(X)5-7	3	1.15	1	115V/208-230V	182TC	450	392	225	67	908	225	21	61	452	392	220	67	910	220	18	58
PVM(X)5-7	3	1.15	3	208-230V/460V	182TC	450	354	225	67	870	225	21	52	452	354	220	67	873	220	18	49
PVM(X)5-8	3	1.15	1	115V/208-230V	182TC	475	392	225	67	933	225	21	61	478	392	220	67	936	220	19	59
PVM(X)5-8	3	1.15	3	208-230V/460V	182TC	475	354	225	67	895	225	21	52	478	354	220	67	898	220	19	50
PVM(X)5-9	3	1.15	1	115V/208-230V	182TC	503	392	225	67	961	225	22	62	505	392	220	67	964	220	19	59
PVM(X)5-9	3	1.15	3	208-230V/460V	182TC	503	354	225	67	923	225	22	53	505	354	220	67	926	220	19	50
PVM(X)5-10	5	1.15	1	208-230V	213TC	533	394	243	79	1006	243	23	76	538	394	243	79	1012	243	20	73
PVM(X)5-10	5	1.15	3	208-230V/460V	184TC	533	354	225	67	954	225	23	53	538	354	225	67	959	225	20	51
PVM(X)5-11	5	1.15	1	208-230V	213TC	561	394	243	79	1034	243	23	76	564	394	243	79	1037	243	21	74
PVM(X)5-11	5	1.15	3	208-230V/460V	184TC	561	354	225	67	982	225	23	54	564	354	225	67	984	225	21	51
PVM(X)5-12	5	1.15	1	208-230V	213TC	587	394	243	79	1060	243	24	77	592	394	243	79	1065	243	21	74
PVM(X)5-12	5	1.15	3	208-230V/460V	184TC	587	354	225	67	1007	225	24	55	592	354	225	67	1012	225	21	52
PVM(X)5-13	5	1.15	1	208-230V	213TC	615	394	243	79	1088	243	24	77	620	394	243	79	1093	243	22	75
PVM(X)5-13	5	1.15	3	208-230V/460V	184TC	615	354	225	67	1035	225	24	55	620	354	225	67	1040	225	22	53
PVM(X)5-14	5	1.15	1	208-230V	213TC	643	394	243	79	1116	243	25	78	645	394	243	79	1118	243	22	75
PVM(X)5-14	5	1.15	3	208-230V/460V	184TC	643	354	225	67	1063	225	25	56	645	354	225	67	1066	225	22	53
PVM(X)5-15	5	1.15	1	208-230V	213TC	668	394	243	79	1141	243	26	79	673	394	243	79	1146	243	23	76
PVM(X)5-15	5	1.15	3	208-230V/460V	184TC	668	354	225	67	1089	225	26	56	673	354	225	67	1094	225	23	54
PVM(X)5-16	5	1.15	1	208-230V	213TC	696	394	243	79	1169	243	26	79	699	394	243	79	1172	243	24	77
PVM(X)5-16	5	1.15	3	208-230V/460V	184TC	696	354	225	67	1116	225	26	57	699	354	225	67	1119	225	24	54
PVM(X)5-18	7.5	1.15	1	208-230V	213TC	747	394	220	79	1220	220	27	80	747	394	220	79	1220	220	25	78
PVM(X)5-18	7.5	1.15	3	208-230V/460V	213TC	747	395	243	79	1221	243	27	72	747	395	243	79	1221	243	25	69
PVM(X)5-20	7.5	1.15	1	208-230V	213TC	800	394	220	79	1273	220	28	82	803	394	220	79	1276	220	26	79
PVM(X)5-20	7.5	1.15	3	208-230V/460V	213TC	546	395	243	79	1020	243	28	73	803	395	243	79	1277	243	26	70
PVM(X)5-22	7.5	1.15	1	208-230V	213TC	853	394	220	79	1327	220	30	83	859	394	220	79	1332	220	27	80
PVM(X)5-22	7.5	1.15	3	208-230V/460V	213TC	853	395	243	79	1328	243	30	74	859	395	243	79	1333	243	27	72
PVM(X)5-24	7.5	1.15	1	208-230V	213TC	907	394	220	79	1380	220	31	84	912	394	220	79	1385	220	28	81
PVM(X)5-24	7.5	1.15	3	208-230V/460V	213TC	907	395	243	79	1381	243	31	75	912	395	243	79	1386	243	28	73

PVM(X) 5 VERTICAL MULTISTAGE CENTRIFUGAL PUMPS

PUMP DIMENSIONS – METRIC

PVM

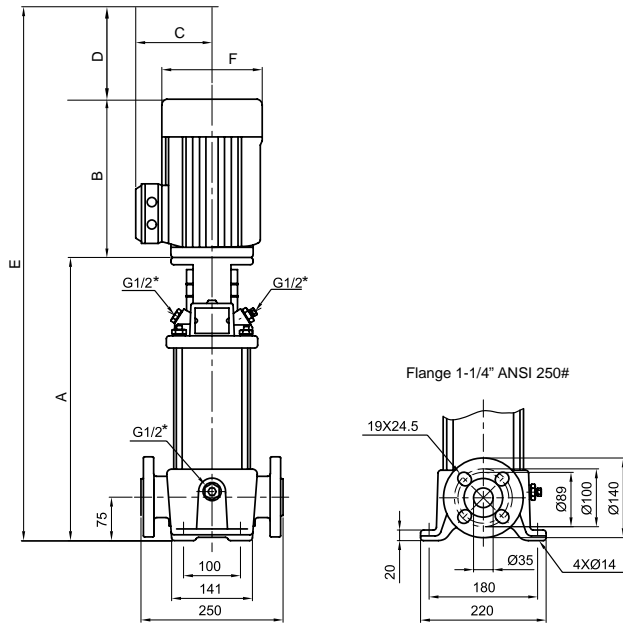

*G1/2 per ISO-228

PVMX

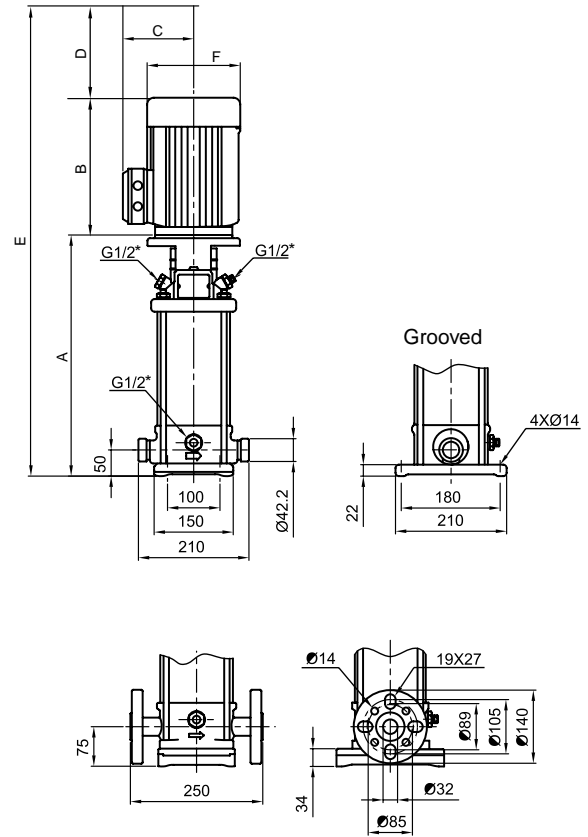

Flange 1-1/4" ANSI 300#

PVM(X) 5

VERTICAL MULTISTAGE CENTRIFUGAL PUMPS

HYDRAULIC PERFORMANCE

Curve PVM(X) 5
Date 10/01/14

Nominal RPM: **3500**
Based on Fresh Water@ **68 deg. F**
Maximum Working Pressure: **266 PSI**

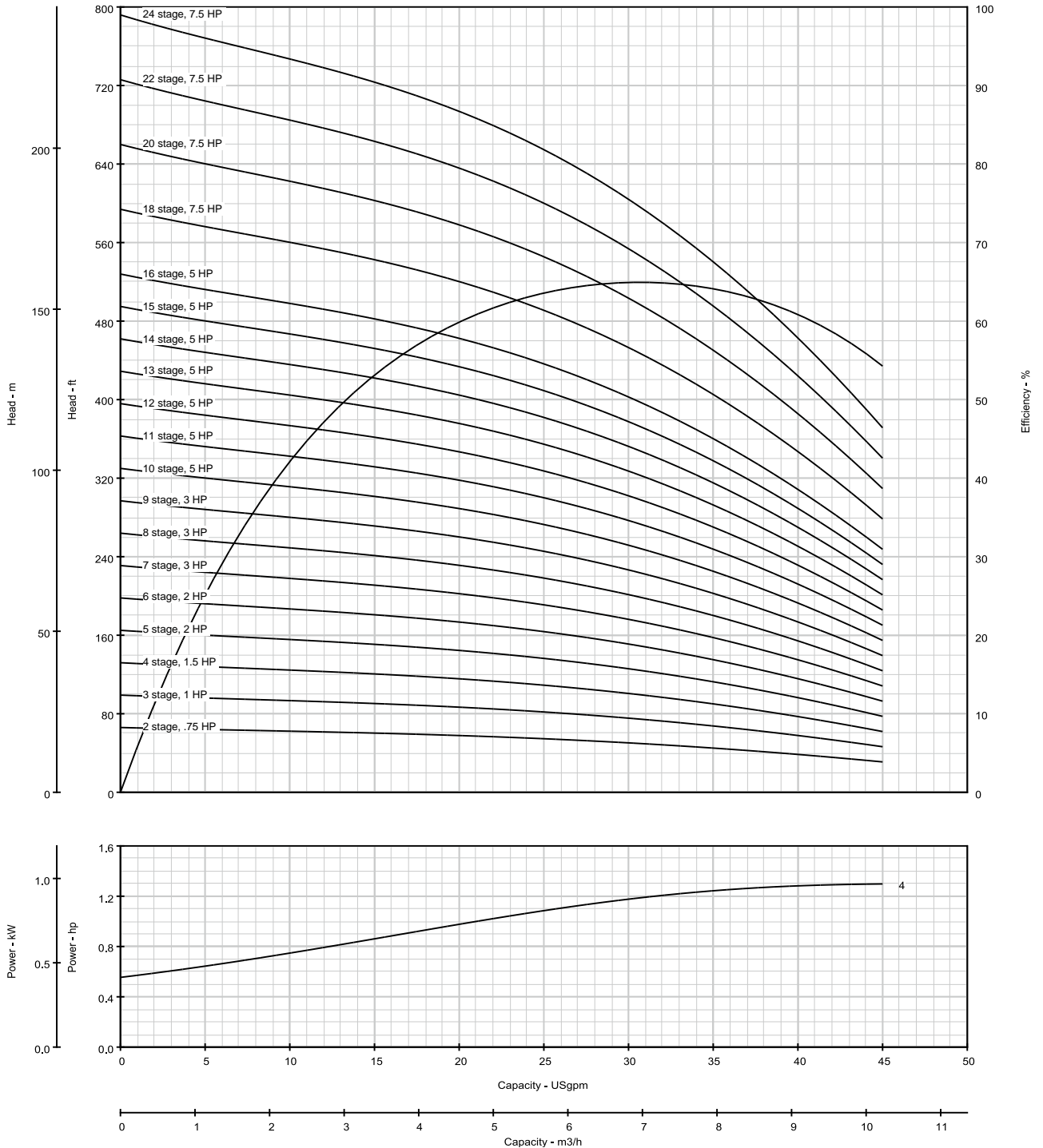

THIS PAGE INTENTIONALLY LEFT BLANK

PVM(X) 10

VERTICAL MULTISTAGE CENTRIFUGAL PUMPS

PUMP DIMENSIONS – STANDARD

Model Number	Motor HP	Motor Service Factor	Phase	Voltage	Motor Frame	PVM Cast Iron							PVMX Stainless Steel								
						Dimensions in inches						Weight in Lbs		Dimensions in inches						Weight in Lbs	
						A	B	C	D	E	F	Pump End Only	Pump & Motor	A	B	C	D	E	F	Pump End Only	Pump & Motor
PVM(X)10-1	0.75	1.25	1	115V/208-230V	56C	13.7	9.9	6.0	2.1	25.7	6.0	61	90	14.1	9.9	6.0	2.1	26.1	6.0	50	79
PVM(X)10-1	0.75	1.25	3	208-230V/460V	56C	13.7	10.2	6.6	2.1	25.9	6.6	61	91	14.1	10.2	6.6	2.1	26.3	6.6	50	80
PVM(X)10-2	1.5	1.15	1	115V/208-230V	56C	14.3	11.2	7.2	2.1	27.5	7.2	67	113	14.7	11.2	7.2	2.1	27.9	7.2	56	102
PVM(X)10-2	1.5	1.15	3	208-230V/460V	56C	14.3	11.2	7.2	2.1	27.5	7.2	67	109	14.7	11.2	7.2	2.1	27.9	7.2	56	98
PVM(X)10-3	3	1.15	1	115V/208-230V	182TC	16.0	15.4	8.9	2.6	34.0	8.9	74	162	16.4	15.4	8.7	2.6	34.4	8.7	63	151
PVM(X)10-3	3	1.15	3	208-230V/460V	182TC	16.0	13.9	8.9	2.6	32.6	8.9	74	142	16.4	13.9	8.7	2.6	33.0	8.7	63	131
PVM(X)10-4	3	1.15	1	115V/208-230V	182TC	17.4	15.4	8.9	2.6	35.4	8.9	80	168	17.7	15.4	8.7	2.6	35.7	8.7	69	157
PVM(X)10-4	3	1.15	3	208-230V/460V	182TC	17.4	13.9	8.9	2.6	34.0	8.9	80	148	17.7	13.9	8.7	2.6	34.3	8.7	69	137
PVM(X)10-5	5	1.15	1	208-230V	213TC	18.5	15.5	9.6	3.1	37.1	9.6	86	203	18.9	15.5	9.6	3.1	37.5	9.6	75	192
PVM(X)10-5	5	1.15	3	208-230V/460V	184TC	18.5	13.9	8.9	2.6	35.1	8.9	86	154	18.9	13.9	8.9	2.6	35.5	8.9	75	143
PVM(X)10-6	5	1.15	1	208-230V	213TC	19.7	15.5	9.6	3.1	38.3	9.6	92	209	20.1	15.5	9.6	3.1	38.7	9.6	81	198
PVM(X)10-6	5	1.15	3	208-230V/460V	184TC	19.7	13.9	8.9	2.6	36.3	8.9	92	160	20.1	13.9	8.9	2.6	36.7	8.9	81	149
PVM(X)10-7	7.5	1.15	1	208-230V	213TC	20.9	15.5	8.7	3.1	39.5	8.7	98	215	21.2	15.5	8.7	3.1	39.8	8.7	87	204
PVM(X)10-7	7.5	1.15	3	208-230V/460V	213TC	20.9	15.5	9.6	3.1	39.6	9.6	98	196	21.2	15.5	9.6	3.1	39.9	9.6	87	185
PVM(X)10-8	7.5	1.15	1	208-230V	213TC	22.0	15.5	8.7	3.1	40.6	8.7	104	221	22.4	15.5	8.7	3.1	41.0	8.7	93	210
PVM(X)10-8	7.5	1.15	3	208-230V/460V	213TC	22.0	15.5	9.6	3.1	40.7	9.6	104	202	22.4	15.5	9.6	3.1	41.1	9.6	93	191
PVM(X)10-9	7.5	1.15	1	208-230V	213TC	23.2	15.5	8.7	3.1	41.8	8.7	110	227	23.5	15.5	8.7	3.1	42.1	8.7	99	216
PVM(X)10-9	7.5	1.15	3	208-230V/460V	213TC	23.2	15.5	9.6	3.1	41.9	9.6	110	208	23.6	15.5	9.6	3.1	42.3	9.6	99	197
PVM(X)10-10	7.5	1.15	1	208-230V	213TC	24.4	15.5	8.7	3.1	43.0	8.7	116	233	24.8	15.5	8.7	3.1	43.4	8.7	105	222
PVM(X)10-10	7.5	1.15	3	208-230V/460V	213TC	24.4	15.5	9.6	3.1	43.1	9.6	116	214	24.8	15.5	9.6	3.1	43.5	9.6	105	203
PVM(X)10-12	10	1.15	1	208-230V	215TC	26.8	16.6	9.6	3.1	46.5	9.6	129	264	27.2	16.6	9.6	3.1	46.9	9.6	117	252
PVM(X)10-12	10	1.15	3	208-230V/460V	215TC	26.8	15.5	9.6	3.1	45.5	9.6	129	254	27.2	15.5	9.6	3.1	45.9	9.6	117	242
PVM(X)10-14	15	1.15	3	208-230V/460V	254TC	31.0	20.0	12.9	3.8	54.8	12.9	141	416	31.3	20.0	12.9	3.8	55.1	12.9	130	405
PVM(X)10-16	15	1.15	3	208-230V/460V	254TC	33.3	20.0	12.9	3.8	57.1	12.9	153	428	33.7	20.0	12.9	3.8	57.5	12.9	142	417

PVM(X) 10

VERTICAL MULTISTAGE CENTRIFUGAL PUMPS

PUMP DIMENSIONS – STANDARD

PVM

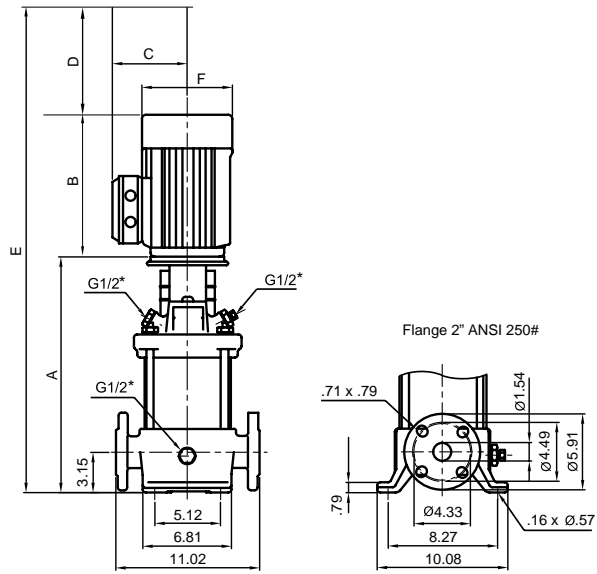

PVMX

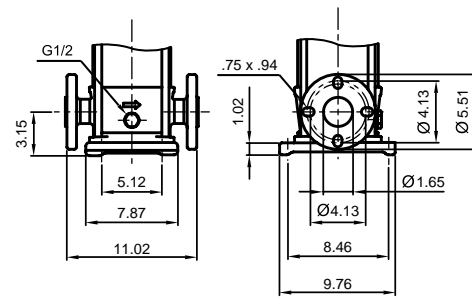
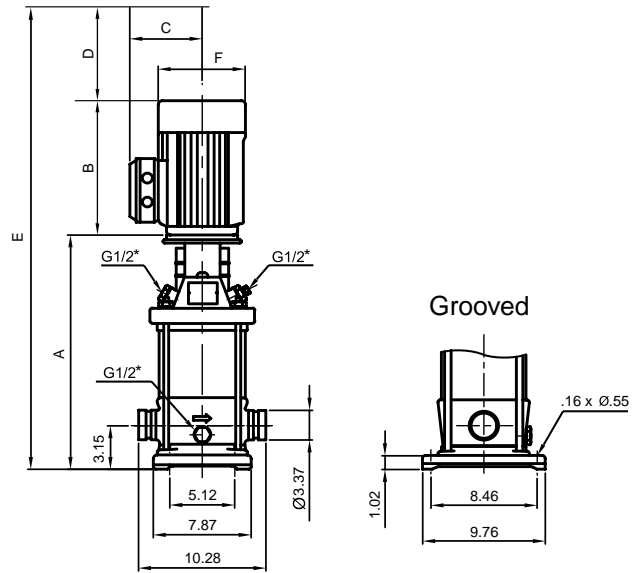

*G1/2 per ISO-228

Flange 2" ANSI 300#

PVM(X) 10

VERTICAL MULTISTAGE CENTRIFUGAL PUMPS

PUMP DIMENSIONS – METRIC

Model Number	Motor HP	Motor Service Factor	Phase	Voltage	Motor Frame	PVM Cast Iron								PVMX Stainless Steel							
						Dimensions in mm						Weight in kgs		Dimensions in mm						Weight in kgs	
						A	B	C	D	E	F	Pump End Only	Pump & Motor	A	B	C	D	E	F	Pump End Only	Pump & Motor
PVM(X)10-1	0.75	1.25	1	115V/208-230V	56C	348	252	153	52	652	153	28	41	358	252	153	52	662	153	23	36
PVM(X)10-1	0.75	1.25	3	208-230V/460V	56C	348	258	168	52	659	168	28	41	358	258	168	52	669	168	23	36
PVM(X)10-2	1.5	1.15	1	115V/208-230V	56C	363	283	182	52	699	182	30	51	373	283	182	52	709	182	25	46
PVM(X)10-2	1.5	1.15	3	208-230V/460V	56C	363	284	183	52	699	183	30	49	373	284	183	52	709	183	25	44
PVM(X)10-3	3	1.15	1	115V/208-230V	182TC	406	392	225	67	865	225	33	73	417	392	220	67	875	220	28	68
PVM(X)10-3	3	1.15	3	208-230V/460V	182TC	406	354	225	67	827	225	33	64	417	354	220	67	837	220	28	59
PVM(X)10-4	3	1.15	1	115V/208-230V	182TC	442	392	225	67	900	225	36	76	450	392	220	67	908	220	31	71
PVM(X)10-4	3	1.15	3	208-230V/460V	182TC	442	354	225	67	862	225	36	67	450	354	220	67	870	220	31	62
PVM(X)10-5	5	1.15	1	208-230V	213TC	470	394	243	79	943	243	39	92	480	394	243	79	953	243	34	87
PVM(X)10-5	5	1.15	3	208-230V/460V	184TC	470	354	225	67	890	225	39	70	480	354	225	67	901	225	34	65
PVM(X)10-6	5	1.15	1	208-230V	213TC	500	394	243	79	973	243	42	95	511	394	243	79	984	243	37	90
PVM(X)10-6	5	1.15	3	208-230V/460V	184TC	500	354	225	67	921	225	42	72	511	354	225	67	931	225	37	67
PVM(X)10-7	7.5	1.15	1	208-230V	213TC	531	394	220	79	1004	220	44	97	538	394	220	79	1012	220	39	92
PVM(X)10-7	7.5	1.15	3	208-230V/460V	213TC	531	395	243	79	1005	243	44	89	538	395	243	79	1013	243	39	84
PVM(X)10-8	7.5	1.15	1	208-230V	213TC	559	394	220	79	1032	220	47	100	569	394	220	79	1042	220	42	95
PVM(X)10-8	7.5	1.15	3	208-230V/460V	213TC	559	395	243	79	1033	243	47	91	569	395	243	79	1043	243	42	86
PVM(X)10-9	7.5	1.15	1	208-230V	213TC	589	394	220	79	1062	220	50	103	597	394	220	79	1070	220	45	98
PVM(X)10-9	7.5	1.15	3	208-230V/460V	213TC	589	395	243	79	1063	243	50	94	599	395	243	79	1074	243	45	89
PVM(X)10-10	7.5	1.15	1	208-230V	213TC	620	394	220	79	1093	220	52	106	630	394	220	79	1103	220	47	100
PVM(X)10-10	7.5	1.15	3	208-230V/460V	213TC	620	395	243	79	1094	243	52	97	630	395	243	79	1104	243	47	92
PVM(X)10-12	10	1.15	1	208-230V	215TC	681	422	243	79	1182	243	58	120	691	422	243	79	1192	243	53	114
PVM(X)10-12	10	1.15	3	208-230V/460V	215TC	681	394	243	79	1155	243	58	115	691	394	243	79	1165	243	53	110
PVM(X)10-14	15	1.15	3	208-230V/460V	254TC	787	509	329	95	1391	329	64	189	795	509	329	95	1399	329	59	184
PVM(X)10-16	15	1.15	3	208-230V/460V	254TC	846	509	329	95	1450	329	69	194	856	509	329	95	1460	329	64	189

PVM(X) 10

VERTICAL MULTISTAGE CENTRIFUGAL PUMPS

PUMP DIMENSIONS - METRIC

PVM

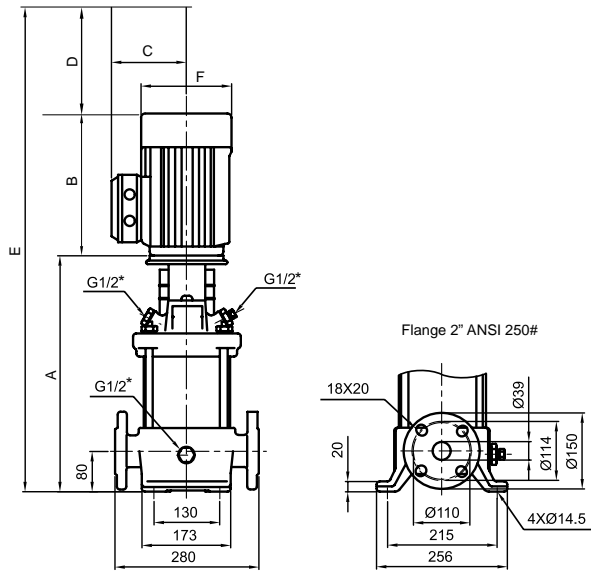

PVMX

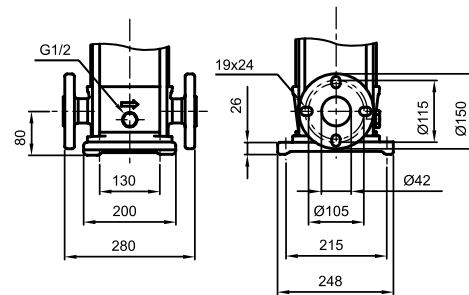
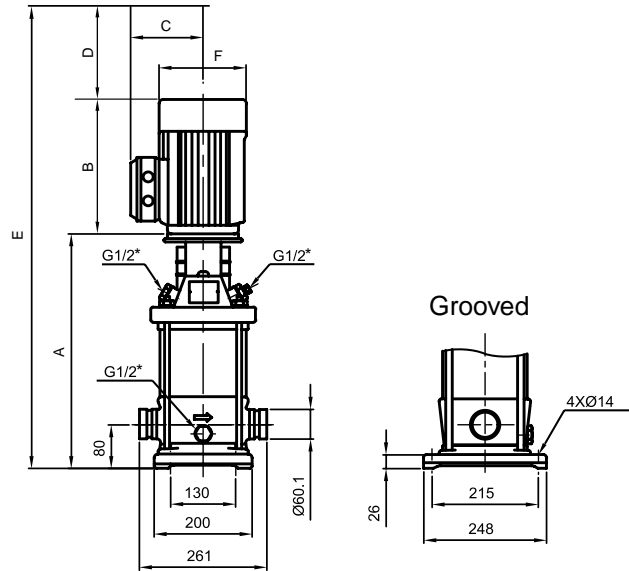

*G1/2 per ISO-228

Flange 2" ANSI 300#

PVM(X) 10

VERTICAL MULTISTAGE CENTRIFUGAL PUMPS

HYDRAULIC PERFORMANCE

Curve PVM(X) 10
Date 10/01/14

Nominal RPM: **3500**
Based on Fresh Water@ 68 deg. F
Maximum Working Pressure: **360 PSI**

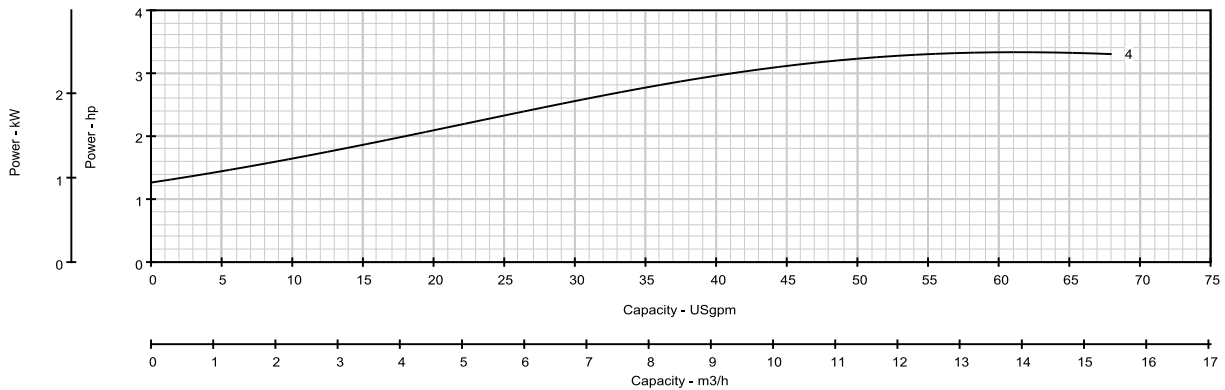
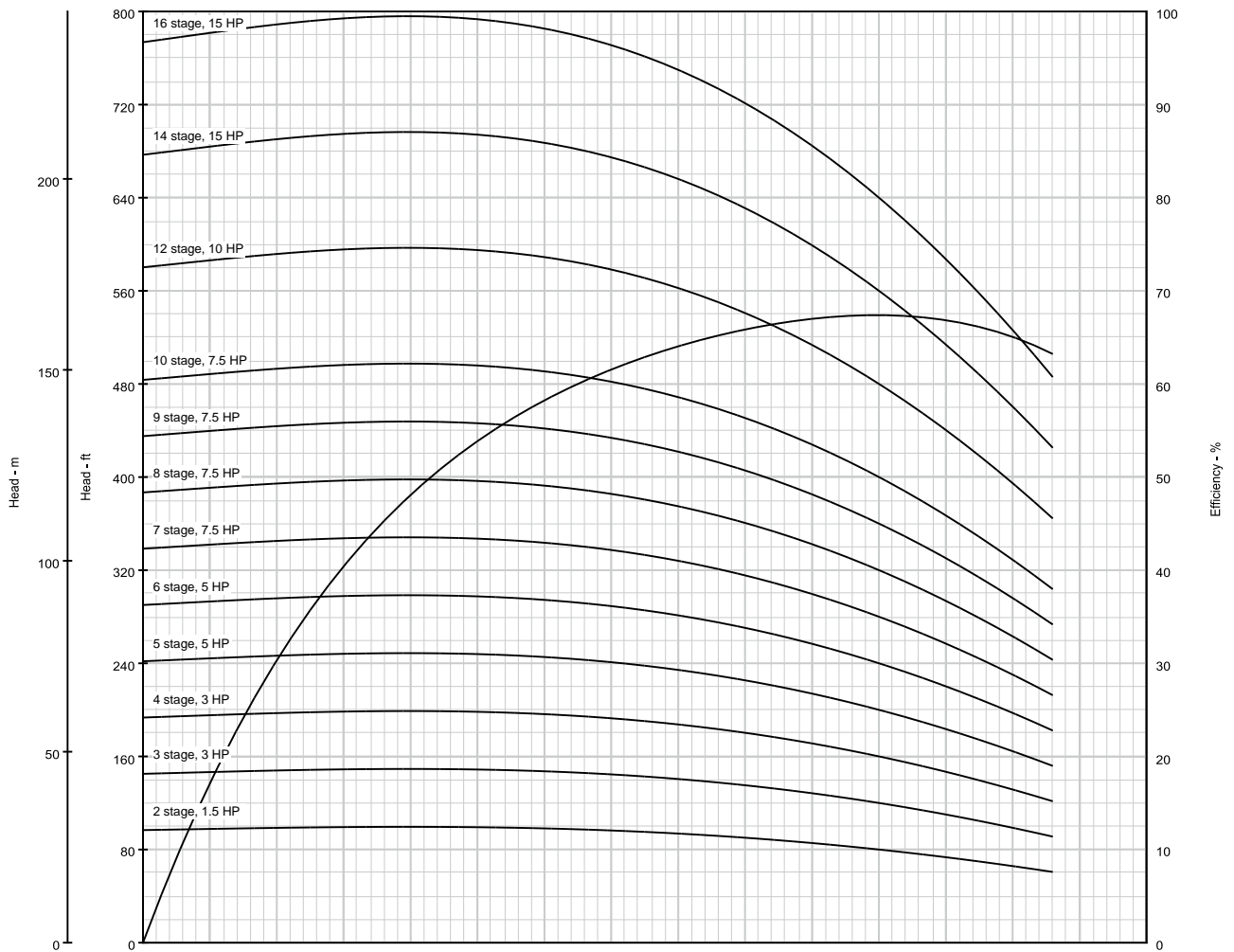

PVM(X) 15

VERTICAL MULTISTAGE CENTRIFUGAL PUMPS

PUMP DIMENSIONS - STANDARD

Model Number	Motor HP	Motor Service Factor	Phase	Voltage	Motor Frame	PVM Cast Iron								PVMX Stainless Steel							
						Dimensions in inches						Weight in Lbs		Dimensions in inches						Weight in Lbs	
						A	B	C	D	E	F	Pump End Only	Pump & Motor	A	B	C	D	E	F	Pump End Only	Pump & Motor
PVM(X)15-1	2	1.15	1	115V/208-230V	56C	16.3	12.1	7.2	2.1	30.4	7.2	65	118	16.3	12.1	7.2	2.1	30.4	7.2	54	107
PVM(X)15-1	2	1.15	3	208-230V/460V	56C	16.3	12.1	7.2	2.1	30.4	7.2	65	114	16.3	12.1	7.2	2.1	30.4	7.2	54	103
PVM(X)15-2	5	1.15	1	208-230V	213TC	17.0	15.5	9.6	3.1	35.6	9.6	76	193	17.0	15.5	9.6	3.1	35.6	9.6	65	182
PVM(X)15-2	5	1.15	3	208-230V/460V	184TC	17.0	13.9	8.9	2.6	33.6	8.9	76	144	17.0	13.9	8.9	2.6	33.6	8.9	65	133
PVM(X)15-3	7.5	1.15	1	208-230V	213TC	17.4	15.5	8.7	3.1	36.0	8.7	86	203	17.3	15.5	8.7	3.1	35.9	8.7	75	192
PVM(X)15-3	7.5	1.15	3	208-230V/460V	213TC	17.4	15.5	9.6	3.1	36.1	9.6	86	184	17.3	15.5	9.6	3.1	36.0	9.6	75	173
PVM(X)15-4	7.5	1.15	1	208-230V	213TC	20.5	15.5	8.7	3.1	39.1	8.7	96	213	19.1	15.5	8.7	3.1	37.7	8.7	85	202
PVM(X)15-4	7.5	1.15	3	208-230V/460V	213TC	20.5	15.5	9.6	3.1	39.2	9.6	96	194	19.1	15.5	9.6	3.1	37.8	9.6	85	183
PVM(X)15-5	10	1.15	1	208-230V	215TC	22.3	16.6	9.6	3.1	42.0	9.6	106	241	22.2	16.6	9.6	3.1	41.9	9.6	95	230
PVM(X)15-5	10	1.15	3	208-230V/460V	215TC	22.3	15.5	9.6	3.1	41.0	9.6	106	231	22.2	15.5	9.6	3.1	40.9	9.6	95	220
PVM(X)15-6	15	1.15	3	208-230V/460V	254TC	25.9	20.0	12.9	3.8	49.7	12.9	117	392	25.8	20.0	12.9	3.8	49.6	12.9	106	381
PVM(X)15-7	15	1.15	3	208-230V/460V	254TC	27.7	20.0	12.9	3.8	51.5	12.9	127	402	27.6	20.0	12.9	3.8	51.4	12.9	116	391
PVM(X)15-8	15	1.15	3	208-230V/460V	254TC	29.5	20.0	12.9	3.8	53.3	12.9	137	412	29.4	20.0	12.9	3.8	53.2	12.9	126	401
PVM(X)15-9	20	1.15	3	230V/460V	254TC	31.2	16.9	10.3	3.8	51.8	10.3	147	372	31.1	16.9	10.3	3.8	51.7	10.3	136	361
PVM(X)15-10	20	1.15	3	230V/460V	254TC	33.0	16.9	10.3	3.8	53.6	10.3	157	382	32.9	16.9	10.3	3.8	53.5	10.3	146	371
PVM(X)15-12	25	1.15	3	230V/460V	284TSC	38.5	20.0	12.9	3.0	61.5	12.9	177	498	38.4	20.0	12.9	3.0	61.4	12.9	166	487

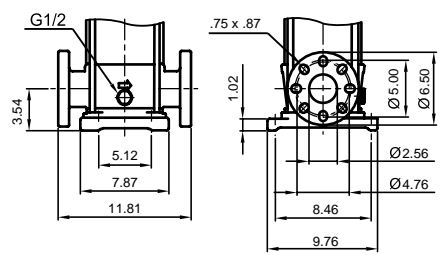
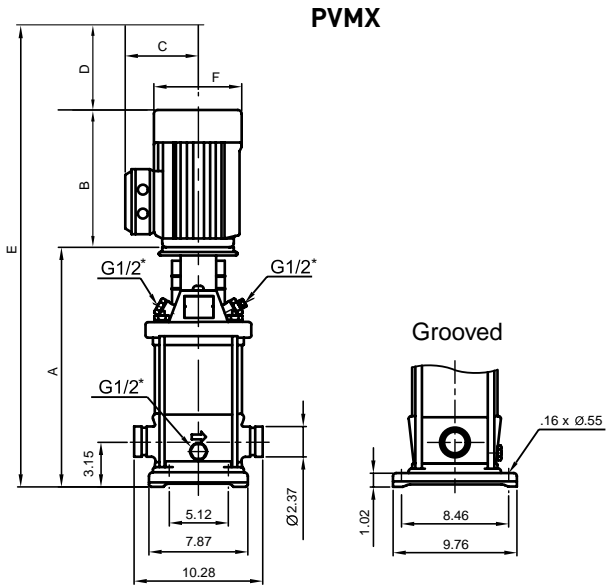
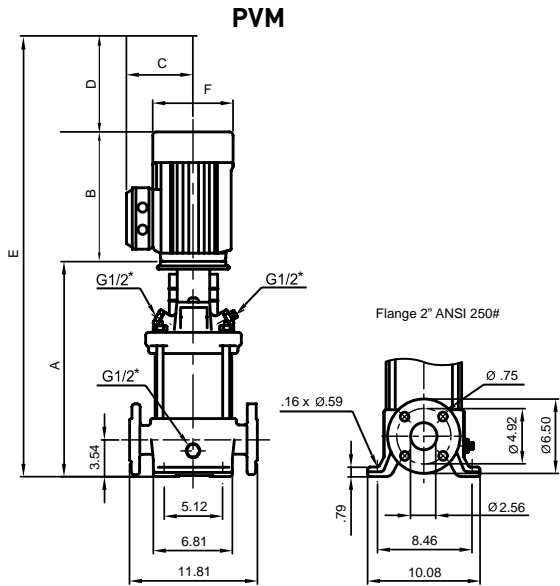

*G1/2 per ISO-228

Flange 2" ANSI 300#

PVM(X) 15

VERTICAL MULTISTAGE CENTRIFUGAL PUMPS

PUMP DIMENSIONS - METRIC

Model Number	Motor HP	Motor Service Factor	Phase	Voltage	Motor Frame	PVM Cast Iron							PVMX Stainless Steel								
						Dimensions in mm						Weight in kgs		Dimensions in mm						Weight in kgs	
						A	B	C	D	E	F	Pump End Only	Pump & Motor	A	B	C	D	E	F	Pump End Only	Pump & Motor
PVM(X)15-1	2	1.15	1	115V/208-230V	56C	414	306	182	52	772	182	29	54	414	306	182	52	772	182	24	48
PVM(X)15-1	2	1.15	3	208-230V/460V	56C	414	306	183	52	772	183	29	52	414	306	183	52	772	183	24	47
PVM(X)15-2	5	1.15	1	208-230V	213TC	432	394	243	79	905	243	34	87	432	394	243	79	905	243	29	82
PVM(X)15-2	5	1.15	3	208-230V/460V	184TC	432	354	225	67	852	225	34	65	432	354	225	67	852	225	29	60
PVM(X)15-3	7.5	1.15	1	208-230V	213TC	442	394	220	79	915	220	39	92	439	394	220	79	912	220	34	87
PVM(X)15-3	7.5	1.15	3	208-230V/460V	213TC	442	395	243	79	916	243	39	83	439	395	243	79	914	243	34	78
PVM(X)15-4	7.5	1.15	1	208-230V	213TC	521	394	220	79	994	220	43	96	485	394	220	79	958	220	38	91
PVM(X)15-4	7.5	1.15	3	208-230V/460V	213TC	521	395	243	79	995	243	43	88	485	395	243	79	959	243	38	83
PVM(X)15-5	10	1.15	1	208-230V	215TC	566	422	243	79	1068	243	48	109	564	422	243	79	1065	243	43	104
PVM(X)15-5	10	1.15	3	208-230V/460V	215TC	566	394	243	79	1040	243	48	105	564	394	243	79	1038	243	43	100
PVM(X)15-6	15	1.15	3	208-230V/460V	254TC	658	509	329	95	1262	329	53	178	655	509	329	95	1259	329	48	173
PVM(X)15-7	15	1.15	3	208-230V/460V	254TC	704	509	329	95	1308	329	58	182	701	509	329	95	1305	329	53	177
PVM(X)15-8	15	1.15	3	208-230V/460V	254TC	749	509	329	95	1353	329	62	187	747	509	329	95	1351	329	57	182
PVM(X)15-9	20	1.15	3	230V/460V	254TC	792	428	263	95	1316	263	67	169	790	428	263	95	1313	263	62	164
PVM(X)15-10	20	1.15	3	230V/460V	254TC	838	428	263	95	1362	263	71	173	836	428	263	95	1359	263	66	168
PVM(X)15-12	25	1.15	3	230V/460V	284TSC	978	507	329	76	1561	329	80	226	975	507	329	76	1559	329	75	221

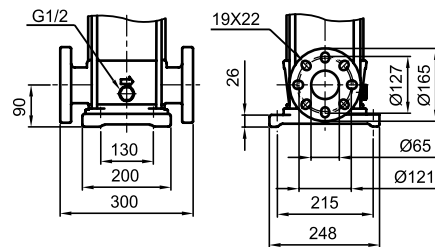
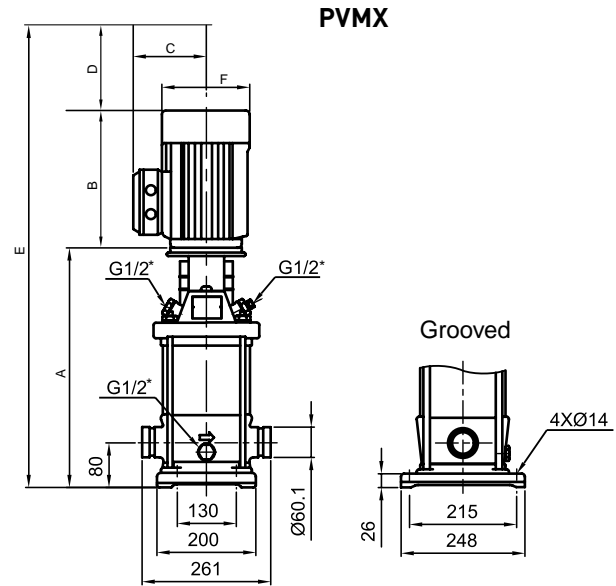
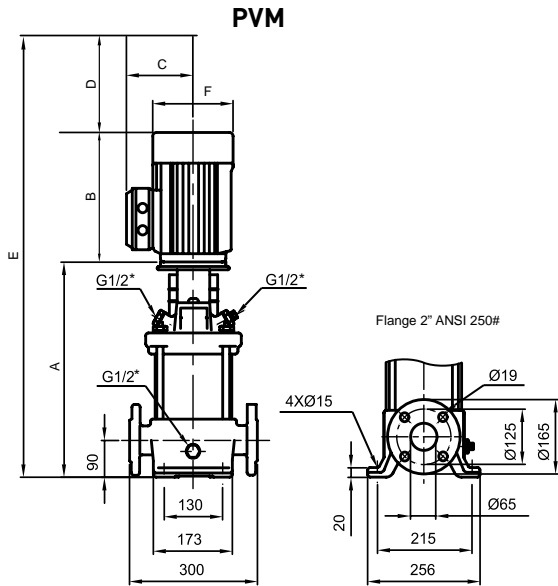

*G1/2 per ISO-228

Flange 2" ANSI 300#

PVM(X) 15

VERTICAL MULTISTAGE CENTRIFUGAL PUMPS

HYDRAULIC PERFORMANCE

Curve PVM(X) 15
Date 10/01/14

Nominal RPM: **3500**
Based on Fresh Water@ **68 deg. F**
Maximum Working Pressure: **266 PSI**

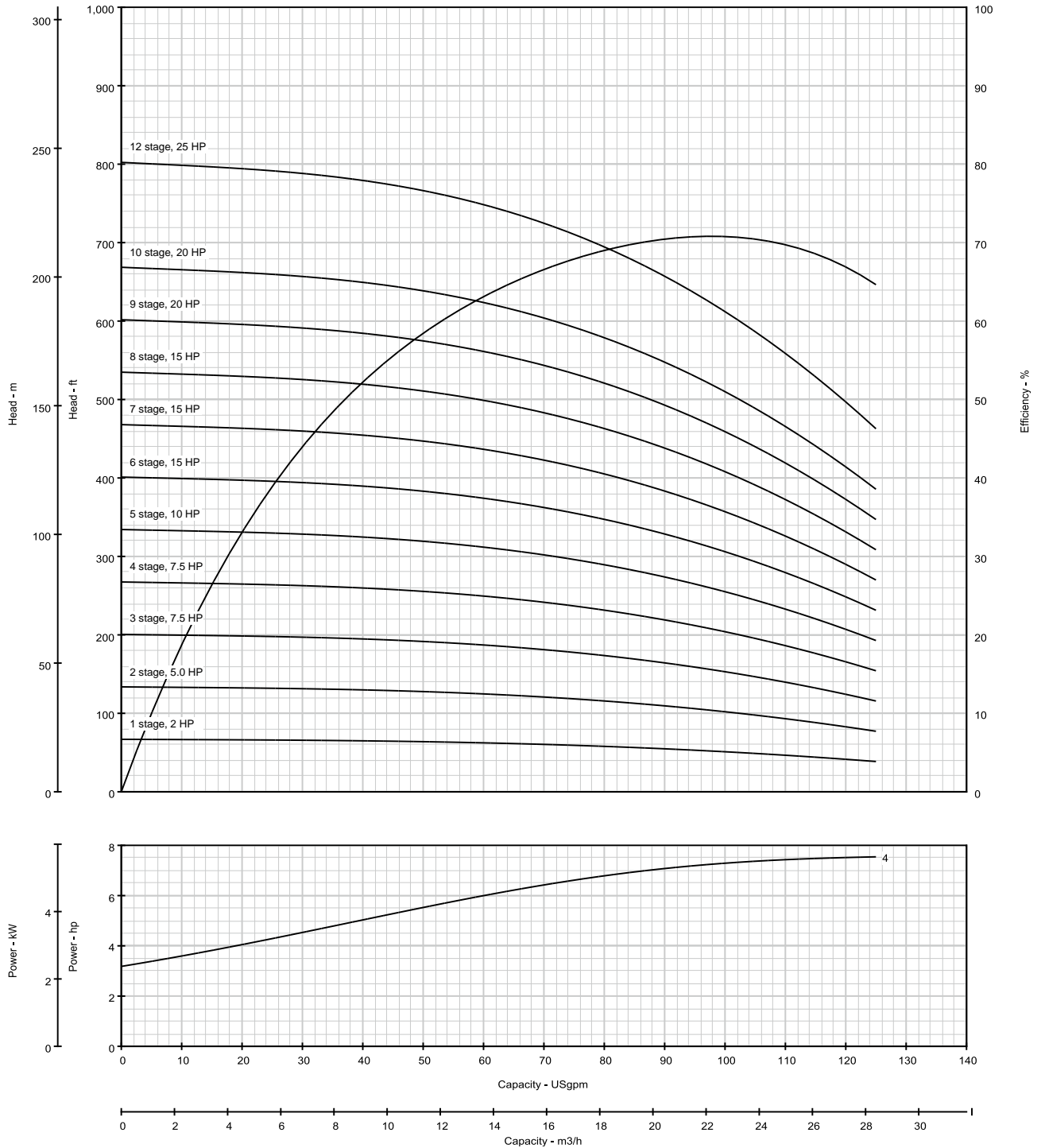

PVM(X) 20

VERTICAL MULTISTAGE CENTRIFUGAL PUMPS

PUMP DIMENSIONS - STANDARD

Model Number	Motor HP	Motor Service Factor	Phase	Voltage	Motor Frame	PVM Cast Iron								PVMX Stainless Steel							
						Dimensions in inches						Weight in Lbs		Dimensions in inches						Weight in Lbs	
						A	B	C	D	E	F	Pump End Only	Pump & Motor	A	B	C	D	E	F	Pump End Only	Pump & Motor
PVM(X)20-1	3	1.15	1	115V/208-230V	182TC	16.8	15.4	8.9	2.6	34.8	8.9	66	154	16.8	15.4	8.7	2.6	34.8	8.7	55	143
PVM(X)20-1	3	1.15	3	208-230V/460V	182TC	16.8	13.9	8.9	2.6	33.4	8.9	66	134	16.8	13.9	8.7	2.6	33.4	8.7	55	123
PVM(X)20-2	5	1.15	1	208-230V	213TC	17.0	15.5	9.6	3.1	35.6	9.6	76	193	17.0	15.5	9.6	3.1	35.6	9.6	65	182
PVM(X)20-2	5	1.15	3	208-230V/460V	184TC	17.0	13.9	8.9	2.6	33.6	8.9	76	144	17.0	13.9	8.9	2.6	33.6	8.9	65	133
PVM(X)20-3	7.5	1.15	1	208-230V	213TC	18.8	15.5	8.7	3.1	37.4	8.7	86	203	18.8	15.5	8.7	3.1	37.4	8.7	75	192
PVM(X)20-3	7.5	1.15	3	208-230V/460V	213TC	18.8	15.5	9.6	3.1	37.5	9.6	86	184	18.8	15.5	9.6	3.1	37.5	9.6	75	173
PVM(X)20-4	10	1.15	1	208-230V	215TC	20.5	16.6	9.6	3.1	40.2	9.6	96	231	20.5	16.6	9.6	3.1	40.2	9.6	85	220
PVM(X)20-4	10	1.15	3	208-230V/460V	215TC	20.5	15.5	9.6	3.1	39.2	9.6	96	221	20.5	15.5	9.6	3.1	39.2	9.6	85	210
PVM(X)20-5	15	1.15	3	208-230V/460V	254TC	24.1	20.0	12.9	3.8	47.9	12.9	107	382	24.1	20.0	12.9	3.8	47.9	12.9	96	371
PVM(X)20-6	15	1.15	3	208-230V/460V	254TC	25.9	20.0	12.9	3.8	49.7	12.9	117	392	25.9	20.0	12.9	3.8	49.7	12.9	106	381
PVM(X)20-7	20	1.15	3	230V/460V	254TC	27.7	16.9	10.3	3.8	48.3	10.3	127	352	27.7	16.9	10.3	3.8	48.3	10.3	116	341
PVM(X)20-8	20	1.15	3	230V/460V	254TC	29.5	16.9	10.3	3.8	50.1	10.3	137	362	29.5	16.9	10.3	3.8	50.1	10.3	126	351
PVM(X)20-10	25	1.15	3	230V/460V	284TSC	35.0	20.0	12.9	3.0	58.0	12.9	157	478	35.0	20.0	12.9	3.0	58.0	12.9	146	467

PVM

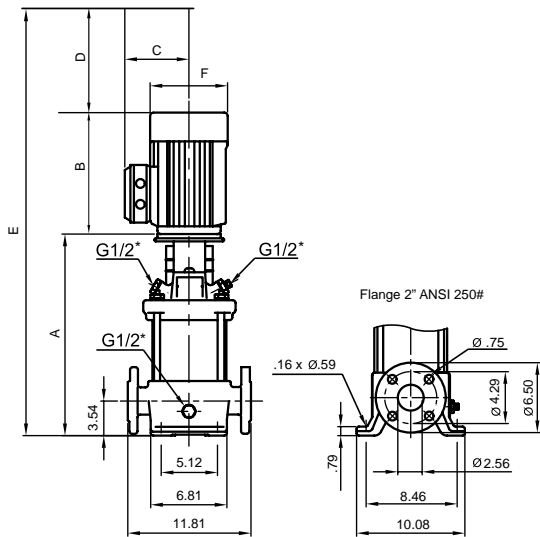

*G1/2 per ISO-228

PVMX

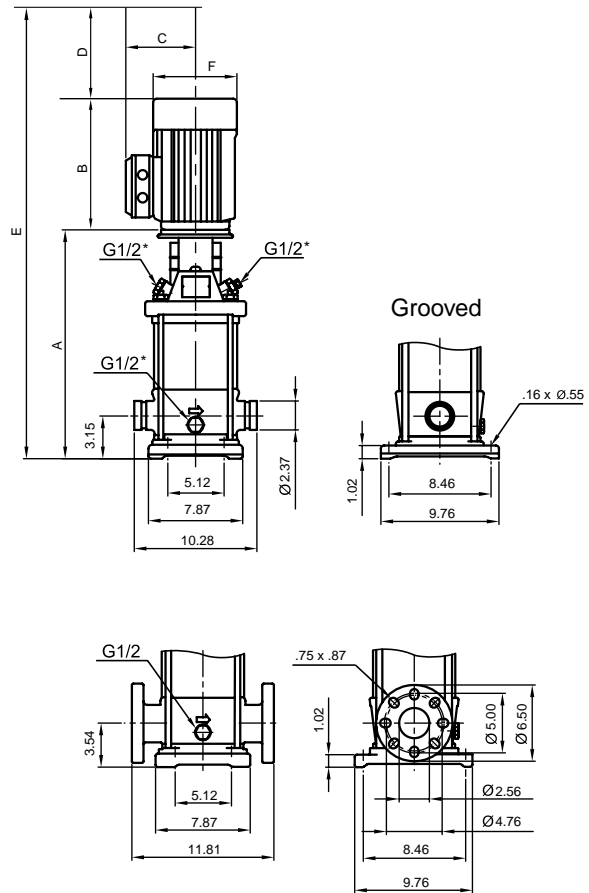

Flange 2" ANSI 300#

PVM(X) 20

VERTICAL MULTISTAGE CENTRIFUGAL PUMPS

PUMP DIMENSIONS - METRIC

Model Number	Motor HP	Motor Service Factor	Phase	Voltage	Motor Frame	PVM Cast Iron							PVMX Stainless Steel								
						Dimensions in mm						Weight in kgs		Dimensions in mm						Weight in kgs	
						A	B	C	D	E	F	Pump End Only	Pump & Motor	A	B	C	D	E	F	Pump End Only	Pump & Motor
PVM(X)20-1	3	1.15	1	115V/208-230V	182TC	427	392	225	67	885	225	30	70	427	392	220	67	885	220	25	65
PVM(X)20-1	3	1.15	3	208-230V/460V	182TC	427	354	225	67	847	225	30	61	427	354	220	67	847	220	25	56
PVM(X)20-2	5	1.15	1	208-230V	213TC	432	394	243	79	905	243	34	87	432	394	243	79	905	243	29	82
PVM(X)20-2	5	1.15	3	208-230V/460V	184TC	432	354	225	67	852	225	34	65	432	354	225	67	852	225	29	60
PVM(X)20-3	7.5	1.15	1	208-230V	213TC	478	394	220	79	951	220	39	92	478	394	220	79	951	220	34	87
PVM(X)20-3	7.5	1.15	3	208-230V/460V	213TC	478	395	243	79	952	243	39	83	478	395	243	79	952	243	34	78
PVM(X)20-4	10	1.15	1	208-230V	215TC	521	422	243	79	1022	243	43	105	521	422	243	79	1022	243	38	100
PVM(X)20-4	10	1.15	3	208-230V/460V	215TC	521	394	243	79	995	243	43	100	521	394	243	79	995	243	38	95
PVM(X)20-5	15	1.15	3	208-230V/460V	254TC	612	509	329	95	1216	329	49	173	612	509	329	95	1216	329	43	168
PVM(X)20-6	15	1.15	3	208-230V/460V	254TC	658	509	329	95	1262	329	53	178	658	509	329	95	1262	329	48	173
PVM(X)20-7	20	1.15	3	230V/460V	254TC	704	428	263	95	1227	263	58	160	704	428	263	95	1227	263	53	155
PVM(X)20-8	20	1.15	3	230V/460V	254TC	749	428	263	95	1273	263	62	164	749	428	263	95	1273	263	57	159
PVM(X)20-10	25	1.15	3	230V/460V	284TSC	889	507	329	76	1472	329	71	217	889	507	329	76	1472	329	66	212

PVM

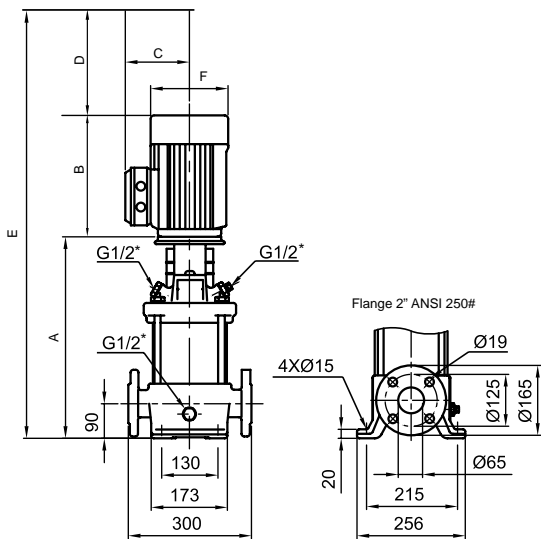

PVMX

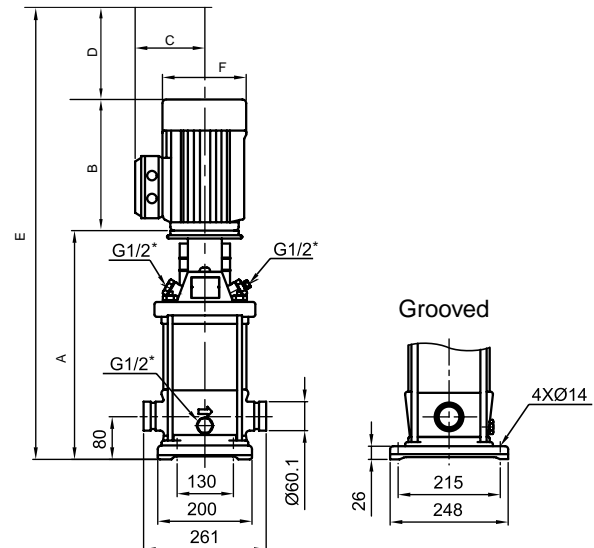

*G1/2 per ISO-228

Flange 2" ANSI 300#

PVM(X) 20

VERTICAL MULTISTAGE CENTRIFUGAL PUMPS

HYDRAULIC PERFORMANCE

Curve PVM(X) 20
Date 10/01/14

Nominal RPM: **3500**
Based on Fresh Water@ **68 deg. F**
Maximum Working Pressure: **360 PSI**

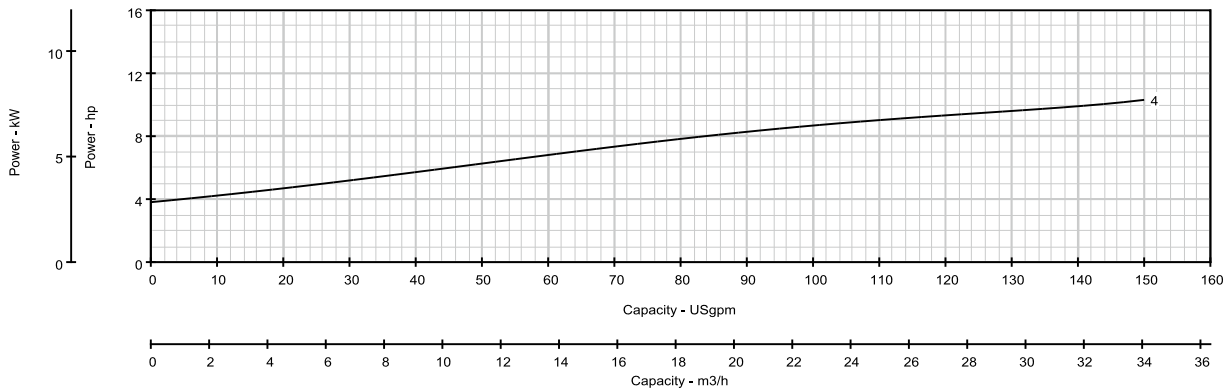
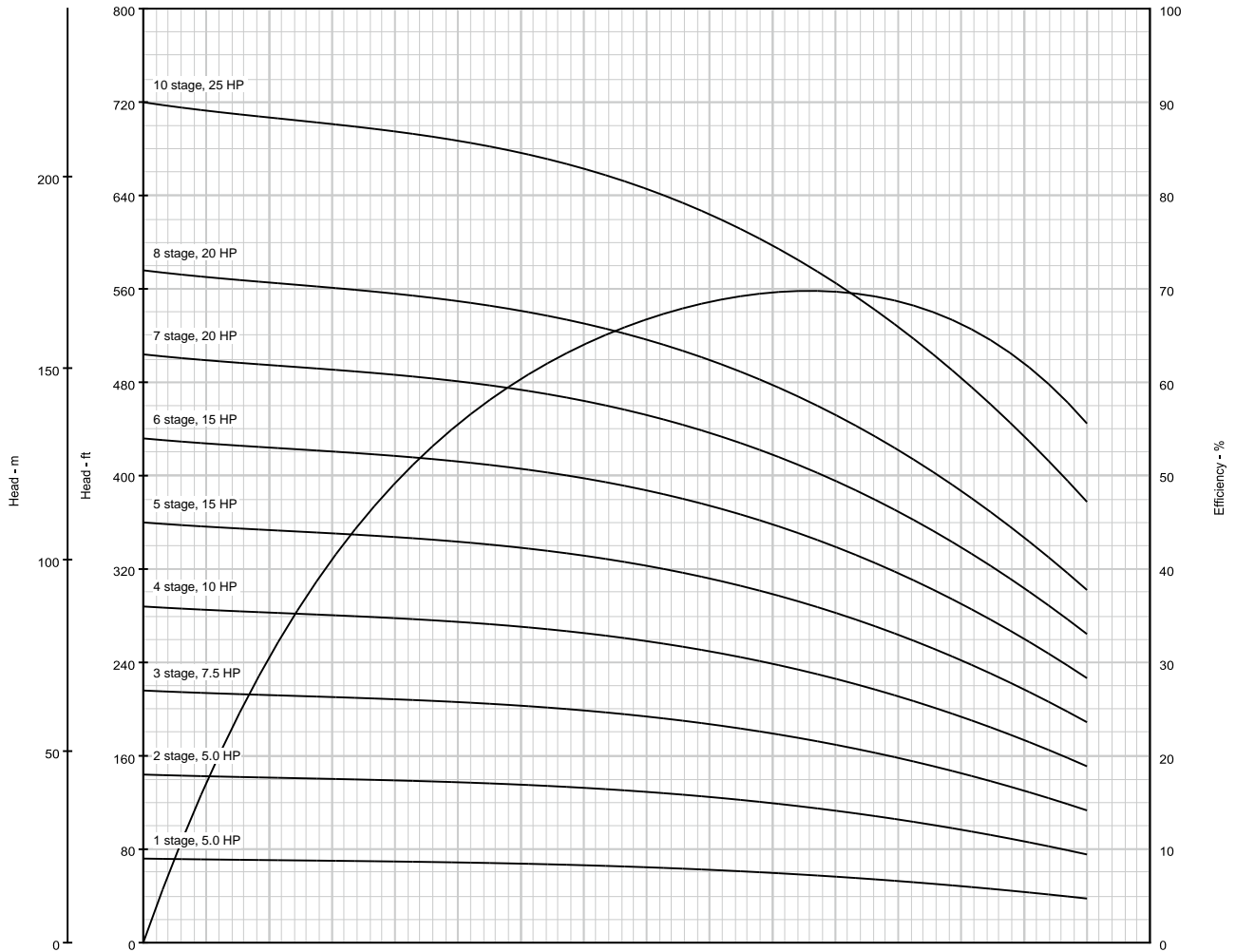

PVM(X) 33

VERTICAL MULTISTAGE CENTRIFUGAL PUMPS

PUMP DIMENSIONS - STANDARD

Model Number	Motor HP	Motor Service Factor	Phase	Voltage	Motor Frame	PVM Cast Iron								PVMX Stainless Steel							
						Dimensions in inches						Weight in Lbs		Dimensions in inches						Weight in Lbs	
						A	B	C	D	E	F	Pump End Only	Pump & Motor	A	B	C	D	E	F	Pump End Only	Pump & Motor
PVM(X)33-1-1	5	1.15	1	208-230V	213TC	20.3	15.5	9.6	3.1	38.9	9.6	130	247	20.3	15.5	9.6	3.1	38.9	9.6	130	247
PVM(X)33-1-1	5	1.15	3	208-230V/460V	184TC	20.3	13.9	8.9	2.6	36.9	8.9	130	198	20.3	13.9	8.9	2.6	36.9	8.9	130	198
PVM(X)33-1	5	1.15	1	208-230V	213TC	20.3	15.5	9.6	3.1	38.9	9.6	130	247	20.3	15.5	9.6	3.1	38.9	9.6	130	247
PVM(X)33-1	5	1.15	3	208-230V/460V	184TC	20.3	13.9	8.9	2.6	36.9	8.9	130	198	20.3	13.9	8.9	2.6	36.9	8.9	130	198
PVM(X)33-2-2	7.5	1.15	1	208-230V	213TC	21.8	15.5	8.7	3.1	40.4	8.7	132	249	21.8	15.5	8.7	3.1	40.4	8.7	132	249
PVM(X)33-2-2	7.5	1.15	3	208-230V/460V	213TC	21.8	15.5	9.6	3.1	40.5	9.6	132	230	21.8	15.5	9.6	3.1	40.5	9.6	132	230
PVM(X)33-2-1	7.5	1.15	1	208-230V	213TC	21.8	15.5	8.7	3.1	40.4	8.7	132	249	21.8	15.5	8.7	3.1	40.4	8.7	132	249
PVM(X)33-2-1	7.5	1.15	3	208-230V/460V	213TC	21.8	15.5	9.6	3.1	40.5	9.6	132	230	21.8	15.5	9.6	3.1	40.5	9.6	132	230
PVM(X)33-2	10	1.15	1	208-230V	215TC	21.8	16.6	9.6	3.1	41.5	9.6	132	267	21.8	16.6	9.6	3.1	41.5	9.6	132	267
PVM(X)33-2	10	1.15	3	208-230V/460V	215TC	21.8	15.5	9.6	3.1	40.5	9.6	132	257	21.8	15.5	9.6	3.1	40.5	9.6	132	257
PVM(X)33-3-2	10	1.15	1	208-230V	215TC	28.9	16.6	9.6	3.1	48.6	9.6	132	267	28.9	16.6	9.6	3.1	48.6	9.6	132	267
PVM(X)33-3-2	10	1.15	3	208-230V/460V	215TC	28.9	15.5	9.6	3.1	47.6	9.6	132	257	28.9	15.5	9.6	3.1	47.6	9.6	132	257
PVM(X)33-3	15	1.15	3	208-230V/460V	254TC	27.7	20.0	12.9	3.8	51.5	12.9	138	413	27.7	20.0	12.9	3.8	51.5	12.9	138	413
PVM(X)33-4-2	15	1.15	3	208-230V/460V	254TC	30.4	20.0	12.9	3.8	54.2	12.9	138	413	30.4	20.0	12.9	3.8	54.2	12.9	138	413
PVM(X)33-4	20	1.15	3	230V/460V	254TC	30.4	16.9	10.3	3.8	51.0	10.3	148	373	30.4	16.9	10.3	3.8	51.0	10.3	148	373
PVM(X)33-5-2	20	1.15	3	230V/460V	254TC	33.2	16.9	10.3	3.8	53.8	10.3	162	387	33.2	16.9	10.3	3.8	53.8	10.3	162	387
PVM(X)33-5	20	1.15	3	230V/460V	254TC	33.2	16.9	10.3	3.8	53.8	10.3	162	387	33.2	16.9	10.3	3.8	53.8	10.3	162	387
PVM(X)33-6-2	25	1.15	3	230V/460V	284TSC	38.0	20.0	12.9	3.0	61.0	12.9	180	501	38.0	20.0	12.9	3.0	61.0	12.9	180	501
PVM(X)33-6	25	1.15	3	230V/460V	284TSC	38.0	20.0	12.9	3.0	61.0	12.9	180	501	38.0	20.0	12.9	3.0	61.0	12.9	180	501
PVM(X)33-7-2	30	1.15	3	230V/460V	284TSC	40.7	23.2	15.6	3.0	66.9	15.6	202	625	40.7	23.2	15.6	3.0	66.9	15.6	202	625
PVM(X)33-7	30	1.15	3	230V/460V	284TSC	40.7	23.2	15.6	3.0	66.9	15.6	202	625	40.7	23.2	15.6	3.0	66.9	15.6	202	625
PVM(X)33-8-2	30	1.15	3	230V/460V	284TSC	43.5	23.2	15.6	3.0	69.7	15.6	228	651	43.5	23.2	15.6	3.0	69.7	15.6	228	651
PVM(X)33-8	40	1.15	3	230V/460V	286TSC	43.5	23.2	15.6	3.0	69.7	15.6	228	708	43.5	23.2	15.6	3.0	69.7	15.6	228	708
PVM(X)33-9-2	40	1.15	3	230V/460V	286TSC	46.2	23.2	15.6	3.0	72.4	15.6	258	738	46.2	23.2	15.6	3.0	72.4	15.6	258	738
PVM(X)33-9	40	1.15	3	230V/460V	286TSC	46.2	23.2	15.6	3.0	72.4	15.6	258	738	46.2	23.2	15.6	3.0	72.4	15.6	258	738
PVM(X)33-10-2	40	1.15	3	230V/460V	286TSC	49.0	23.2	15.6	3.0	75.2	15.6	292	772	49.0	23.2	15.6	3.0	75.2	15.6	292	772

PVM

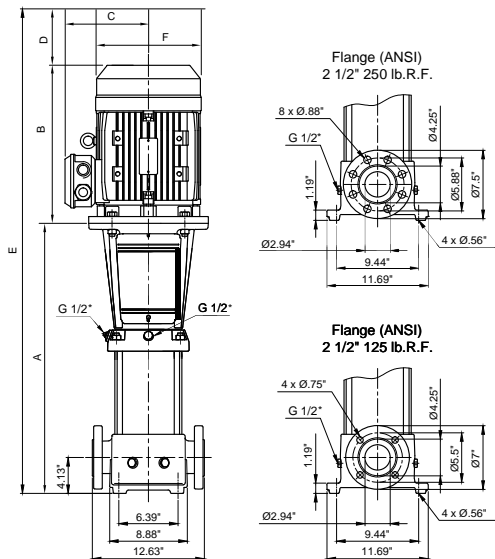

PVMX

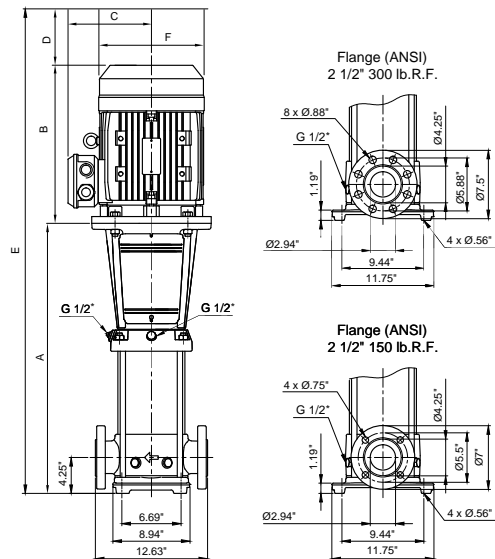

*G1/2 per ISO-228

PVM(X) 33

VERTICAL MULTISTAGE CENTRIFUGAL PUMPS

PUMP DIMENSIONS - METRIC

Model Number	Motor HP	Motor Service Factor	Phase	Voltage	Motor Frame	PVM Cast Iron							PVMX Stainless Steel								
						Dimensions in mm						Weight in kgs		Dimensions in mm						Weight in kgs	
						A	B	C	D	E	F	Pump End Only	Pump & Motor	A	B	C	D	E	F	Pump End Only	Pump & Motor
PVM(X)33-1-1	5	1.15	1	208-230V	213TC	516	394	243	79	989	243	59	112	516	394	243	79	989	243	59	112
PVM(X)33-1-1	5	1.15	3	208-230V/460V	184TC	516	354	225	67	936	225	59	90	516	354	225	67	936	225	59	90
PVM(X)33-1	5	1.15	1	208-230V	213TC	516	394	243	79	989	243	59	112	516	394	243	79	989	243	59	112
PVM(X)33-1	5	1.15	3	208-230V/460V	184TC	516	354	225	67	936	225	59	90	516	354	225	67	936	225	59	90
PVM(X)33-2-2	7.5	1.15	1	208-230V	213TC	554	394	220	79	1027	220	60	113	554	394	220	79	1027	220	60	113
PVM(X)33-2-2	7.5	1.15	3	208-230V/460V	213TC	554	395	243	79	1028	243	60	104	554	395	243	79	1028	243	60	104
PVM(X)33-2-1	7.5	1.15	1	208-230V	213TC	554	394	220	79	1027	220	60	113	554	394	220	79	1027	220	60	113
PVM(X)33-2-1	7.5	1.15	3	208-230V/460V	213TC	554	395	243	79	1028	243	60	104	554	395	243	79	1028	243	60	104
PVM(X)33-2	10	1.15	1	208-230V	215TC	554	422	243	79	1055	243	60	121	554	422	243	79	1055	243	60	121
PVM(X)33-2	10	1.15	3	208-230V/460V	215TC	554	394	243	79	1028	243	60	117	554	394	243	79	1028	243	60	117
PVM(X)33-3-2	10	1.15	1	208-230V	215TC	734	422	243	79	1236	243	60	121	734	422	243	79	1236	243	60	121
PVM(X)33-3-2	10	1.15	3	208-230V/460V	215TC	734	394	243	79	1208	243	60	117	734	394	243	79	1208	243	60	117
PVM(X)33-3	15	1.15	3	208-230V/460V	254TC	704	509	329	95	1308	329	63	187	704	509	329	95	1308	329	63	187
PVM(X)33-4-2	15	1.15	3	208-230V/460V	254TC	772	509	329	95	1376	329	63	187	772	509	329	95	1376	329	63	187
PVM(X)33-4	20	1.15	3	230V/460V	254TC	772	428	263	95	1296	263	67	169	772	428	263	95	1296	263	67	169
PVM(X)33-5-2	20	1.15	3	230V/460V	254TC	843	428	263	95	1367	263	73	176	843	428	263	95	1367	263	73	176
PVM(X)33-5	20	1.15	3	230V/460V	254TC	843	428	263	95	1367	263	73	176	843	428	263	95	1367	263	73	176
PVM(X)33-6-2	25	1.15	3	230V/460V	284TSC	965	507	329	76	1549	329	82	227	965	507	329	76	1549	329	82	227
PVM(X)33-6	25	1.15	3	230V/460V	284TSC	965	507	329	76	1549	329	82	227	965	507	329	76	1549	329	82	227
PVM(X)33-7-2	30	1.15	3	230V/460V	284TSC	1034	589	395	76	1699	395	92	283	1034	589	395	76	1699	395	92	283
PVM(X)33-7	30	1.15	3	230V/460V	284TSC	1034	589	395	76	1699	395	92	283	1034	589	395	76	1699	395	92	283
PVM(X)33-8-2	30	1.15	3	230V/460V	284TSC	1105	589	395	76	1770	395	103	295	1105	589	395	76	1770	395	103	295
PVM(X)33-8	40	1.15	3	230V/460V	286TSC	1105	589	395	76	1770	395	103	321	1105	589	395	76	1770	395	103	321
PVM(X)33-9-2	40	1.15	3	230V/460V	286TSC	1173	589	395	76	1839	395	117	335	1173	589	395	76	1839	395	117	335
PVM(X)33-9	40	1.15	3	230V/460V	286TSC	1173	589	395	76	1839	395	117	335	1173	589	395	76	1839	395	117	335
PVM(X)33-10-2	40	1.15	3	230V/460V	286TSC	1245	589	395	76	1910	395	132	350	1245	589	395	76	1910	395	132	350

PVM

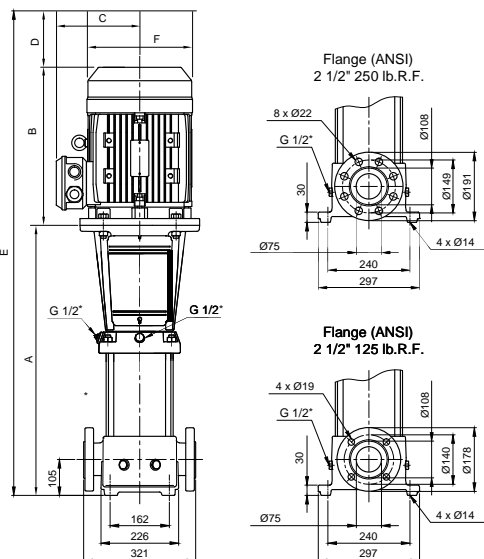

PVMX

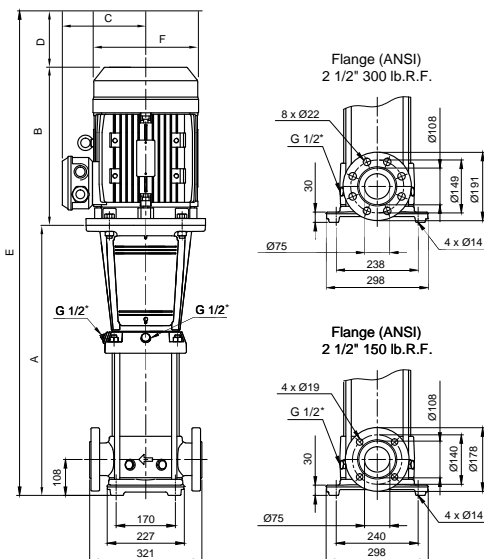

*G1/2 per ISO-228

PVM(X) 33

VERTICAL MULTISTAGE CENTRIFUGAL PUMPS

HYDRAULIC PERFORMANCE

Curve PVM(X) 33
Date 10/01/14

Nominal RPM: **3500**
Based on Fresh Water@ 68 deg. F
Maximum Working Pressure: **435 PSI**

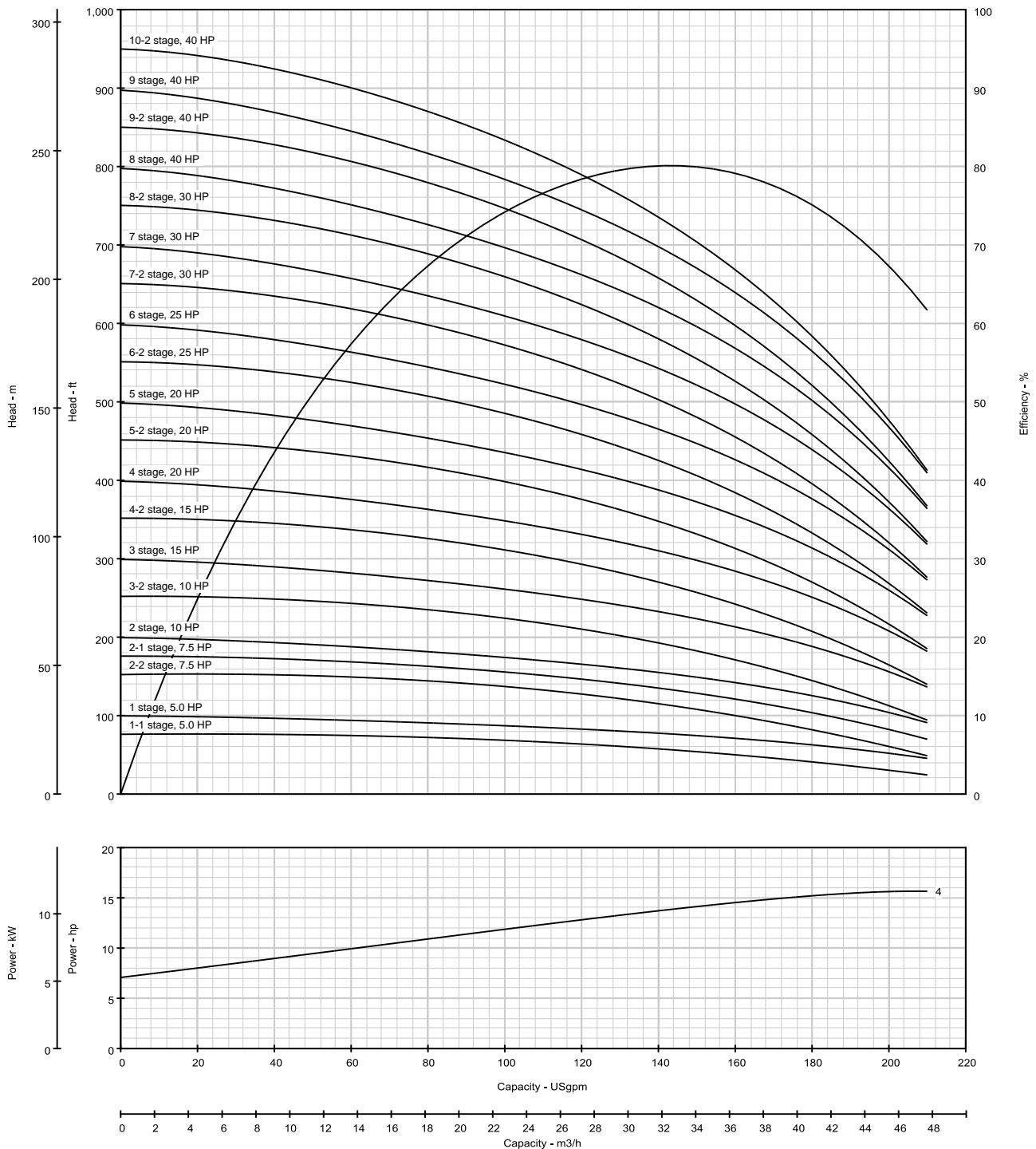

THIS PAGE INTENTIONALLY LEFT BLANK



WATER ENERGY

WE PUT ENERGY INTO YOUR WATER

Pentair has been committed to the design and production of electric water pumps providing our customers with quality products and concrete solutions for all their needs. Within the wide Pentair supply range, engineering firms and plumbing and heating/cooling distributing centres can find products and systems which meet any need with regards to water supply and pressurization in the realm of residential and commercial building, irrigation and industry applications.



FIRE-FIGHTING SYSTEMS AND PRESSURIZATION SYSTEMS

Vertical and horizontal centrifugal pumps. Complete systems for the transfer and pressurization of water. Fire-fighting systems.



ELECTRIC PUMPS FOR RESIDENTIAL USE

Submersible pumps, self-priming pumps, multistage centrifugal pumps and compacting pumping systems for domestic water supply, irrigation and the re-utilization of harvested rainwater.



ELECTRIC PUMPS FOR DRAINAGE

Pumps for the transfer of clear, dirty and wastewaters and sewage. Pumps for numerous applications (water in basins, tanks, pumping stations etc.)



ELECTRIC PUMPS FOR OPEN AND DRILLED WELLS

Submersible pumps for irrigation and pumping underground waters.



800 AIRPORT ROAD, NORTH AURORA, ILLINOIS · PH: 630-859-7000 · www.AuroraPump.com

Because we are continuously improving our products and services, Pentair reserves the right to change specifications without prior notice.

© 2015 Pentair Ltd. All Rights Reserved.

A-02-1078 (01/30/15)